

NOTES:

1. SEE DRAWING DT-D-87-904-1 FOR PLAN VIEW & ELEVATION.

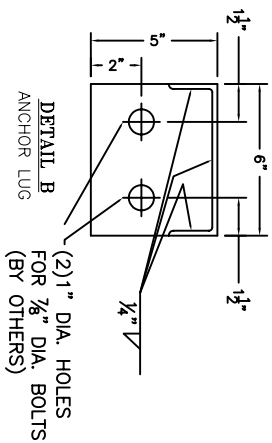

DATE	SW	REVISION	APPROV	CHK
2/28/02	A	REV. INLET	BLO	JF
4/8/02	B	REV. OUTLET & POCKETS	BLO	JF
1/28/03	C	ADDED ANCHOR LUG DETAILS	GT	JF
8/29/05	D	ADD DIM., ELEVATION TABLE	KF	JBH
9/19/06	E	MOD. MAKE-UP ANCHOR BOLTS	KF	JBH
4/14/09	F	REVISED HEIGHT	KF	JBH

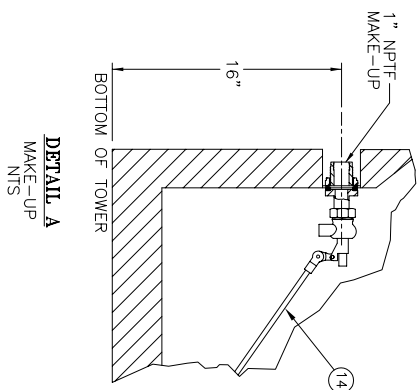
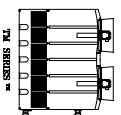

DELTA COOLING TOWERS, INC.
 41 PINE STREET, ROCKAWAY, NJ 07866
 PH 973.586.2201 FAX 973.586.2243

3 CELL

DESIGNED BY *George J. O'Leary*
 APPROVED BY *John Stalder*

SCALE 5/8"=1'-0" DWG NO. **DT-D-87-904-2**
 DATE 6/14/01