



Delta Cooling Towers, Inc.

Premier™ Cooling Tower

Installation, Operation
& Maintenance Manual

Table of Contents

Delta Cooling Towers	Principle of Cooling Towers.....	2
	Cooling Tower Terms and Definitions.....	2
	Water Treatment.....	3
General Information	Safety.....	3
	Approximate Weights.....	4
	Dimensions & Other Physical Data.....	4
Handling & Installation	On-Site Inspection.....	5
	Off Loading.....	5
	Anchoring.....	5
	Tower Internals Pre-Check.....	6
	Electrical Wiring of Fan Motor & Accessories.....	6
	Location, Piping & Connections.....	7
	PVC Solvent Cementing Instructions.....	7
Operation and Maintenance	Safety in Operation of the Fan.....	8
	Water Distribution System.....	8
	Fan & Mechanical Drive System.....	9
	Start-up Instructions.....	9
	Water Level in Tower Sump.....	10
	Cold Weather Operation.....	10
	Trouble-Shooting Guide.....	13
Motor Trouble-Shooting Guide.....	15	
Other Information	Cooling Tower Optional Accessories.....	16
	Recommended Replacement Parts.....	16
	Preventative Maintenance Checklist.....	17
	Warranty.....	18

Important: Delta’s cooling towers have been designed to provide trouble-free service over an extended period of time. To obtain the design performance, it is necessary that the cooling tower be installed, operated and maintained as prescribed in these instructions.

Only persons possessing the skill and experience described herein should attempt to install this equipment. **Prior to installation, these instructions should be read carefully** by the person who is to install the cooling tower to be certain that its installation, operation and maintenance are thoroughly understood.

Questions regarding the installation, operation or maintenance of this equipment should be directed to Delta Cooling Towers, Inc., Rockaway, New Jersey, (Telephone: 973/586-2201).

Step-by-step instructions contained in this brochure are based on normal installation conditions only. Abnormal or unusual combinations of field conditions should be brought to the attention of Delta Cooling Towers or its representative prior to installation of the equipment. The information contained herein is subject to change without notice in the interest of product improvement.

Rev. 9/21/06

Delta Cooling Towers

Principle of Cooling Towers

All Cooling Towers operate on the principle of removing heat from water by evaporating a small portion of the water that is recirculated through the unit.

The heat that is removed is called the latent heat of vaporization.

Each one pound of water that is evaporated removes approximately 1,000 BTU's in the form of latent heat.

Cooling Tower Terms and Definitions

BTU - A BTU is the heat energy required to raise the temperature of one pound of water one degree Fahrenheit in the range from 32° F. to 212° F.

Cooling Range - The difference in temperature between the hot water entering the tower and the cold water leaving the tower is the cooling range.

Approach - The difference between the temperature of the cold water leaving the tower and the wet-bulb temperature of the air is known as the approach. Establishment of the approach fixes the operating temperature of the tower and is a most important parameter in determining both tower size and cost.

Drift - The water entrained in the air flow and discharged to the atmosphere. Drift loss does not include water lost by evaporation. Proper tower design and operation can minimize drift loss.

Heat Load - The amount of heat to be removed from the circulating water within the tower. Heat load is equal to water circulation rate (gpm) times the cooling range times 500 and is expressed in BTU/hr. Heat load is also an important parameter in determining tower size and cost.

Ton - An evaporative cooling ton is 15,000 BTU's per hour.

Wet-Bulb Temperature - The lowest temperature that water theoretically can reach by evaporation. Wet-Bulb Temperature is an extremely important parameter in tower selection and design and should be measured by a psychrometer.

Pumping Head - The pressure required to pump the water from the tower basin, through the entire system and return to the top of the tower.

Make-Up - The amount of water required to replace normal losses caused by bleed-off, drift, and evaporation.

Bleed Off (Blow down) - The circulating water in the tower which is discharged to waste to help keep the dissolved solids concentration of the water below a maximum allowable limit. As a result of evaporation, dissolved solids concentration will continually increase unless reduced by bleed off.

Water Treatment

- The Delta Cooling Tower for the most fabricated of corrosion-resistant plastics which are resistant to water treatment chemicals including common fungicides and bactericides.
- Follow appropriate water treatment practices such as required and take frequent sample tests to avoid possible water contamination. We also recommend water treatment maintenance as a measure of protection for the environment in the vicinity of any cooling tower or other equipment open to atmosphere.
- To determine the appropriate water treatment practices for your particular application, it is suggested that you contact a water treatment firm for their recommendation. A list of water treatment firms is available for your reference. It is not necessarily complete nor do we recommend a specific firm. The list will be mailed to you on request or consult your local yellow pages.
- Bleed-off also important to water quality. Evaporation of the recirculated water does not remove the dissolved solids that are present in the water. Without bleed-off, the continual buildup of these solids will impair the proper functioning of the piping and other equipment in the system.
- A bleed line can be connected in any part of the system with routing to the sewer. Normally, it is most desirable to make this connection in the hot water line at the cooling tower. A petcock type valve, installed in the bleed line is recommended. Normally, bleed-off of 1% to 2% of the recirculation water flow is satisfactory. The required amount of bleed-off water must be substituted with properly controlled amounts of make-up water.

General Information

Safety

When handling, lifting, installing or operating the cooling tower, always employ safe work procedures, according to best practices of the trade and according to applicable construction, electrical and safety standards, regulations and codes.

Follow all safety practices described in these instructions.

Approximate Weights

The induced draft cooling towers are manufactured in two basic sections: a polyethylene tower body and a fan assembly section. Both of these sections are factory assembled and shipped as a complete unit, eliminating field assembly.

Approximate Weights (lbs.)			Overall Dimensions (inch)
Model #	Shipping	Operating	W x L x H
ΔTR-205812	3,900	7,990	101" x 180" x 131"
ΔTR-275812	3,980	8,140	101" x 180" x 131"
ΔTR-210812	4,100	8,300	101" x 180" x 131"
ΔTR-305812	6,050	11,960	101" x 258" x 131"
ΔTR-375812	6,170	12,150	101" x 258" x 131"
ΔTR-310812	6,350	12,430	101" x 258" x 131"

Dimensions and Other Physical Data

For cooling tower dimensions, design for foundations, assembly and layout; refer to the following drawings, which are a part of these instructions:

Model #	Title	Drawing No.
ΔTR-205812, ΔTR-275812 & ΔTR-210812	Assembly Installation Layout	DT-D-86-930 DT-D-86-911 DT-D-86-913
ΔTR-305812, ΔTR-375812, ΔTR-310812	Assembly Installation Layout	DT-D-86-929 DT-D-86-912 DT-D-86-914

Handling and Installation of Your Premier™ Cooling Tower

On -Site Inspection

Upon arrival at the job site, carefully inspect the shipment of any damage. If shipping damage has occurred, notify the driver or the carrier immediately in writing of all damage. Check that all items listed on the Shipping Bill of Lading have been received.

Offloading

The Premier™ cooling towers are normally delivered to the site on a "30 inch high single drop deck" trailer. The tower assembly is shipped with the steel-mounting frame strapped down to the truck bed. Unload the tower assembly complete with the mounting frame. (See Figure 1)

Lifting with crane:

- Before lifting, inspect the mounting frame to tower connection making certain that the tower is secure, adjust or tighten if necessary.
- Lift tower utilizing the four corner lifting holes on steel mounting base only.
- Use spreader bars to eliminate any crushing effect of slings on the tower or use adequate length straps in order to maintain an angle of 60° or less between slings.
- LIFTING STRAPS OR CHAINS MUST NOT COME IN CONTACT WITH THE TOWER SHELL OR DAMAGE TO THE SHELL IS LIKELY TO OCCUR.

Offloading with fork truck:

- A fork truck of sufficient capacity may be used for offloading. The forks should pass under the skid along the width of the mounting frame with the tips of the fork extensions passing under the mid supports of the mounting frame. A strap should be placed around the tower body and forks to secure the load.
- Fork extensions (about 7 1/2 ft. long) are necessary tower skids.

Store tower assembly as shipped until the time of installation, in a secure location at the job site.

CAUTION: *For extended lifts, use duplicate rigging as an additional safety precaution.*

Anchoring

The foundation must be flat, smooth and rigid enough to be capable of independent support of the cooling tower assembly and water load in the sump at its maximum level. The tower assembly can also be mounted on I-beams or columns per installation drawings.

- Four hold-down anchors are required for the small towers and six for the large tower.
- Attachment hardware to tower mounting frame is by others.
- Use anchor bolts sized for a minimum of 1,500 lbs. pullout load for wind loading.

CRANE OPERATOR ALERT!

HANDLING AND INSTALLATION OF YOUR PREMIER™ COOLING TOWER

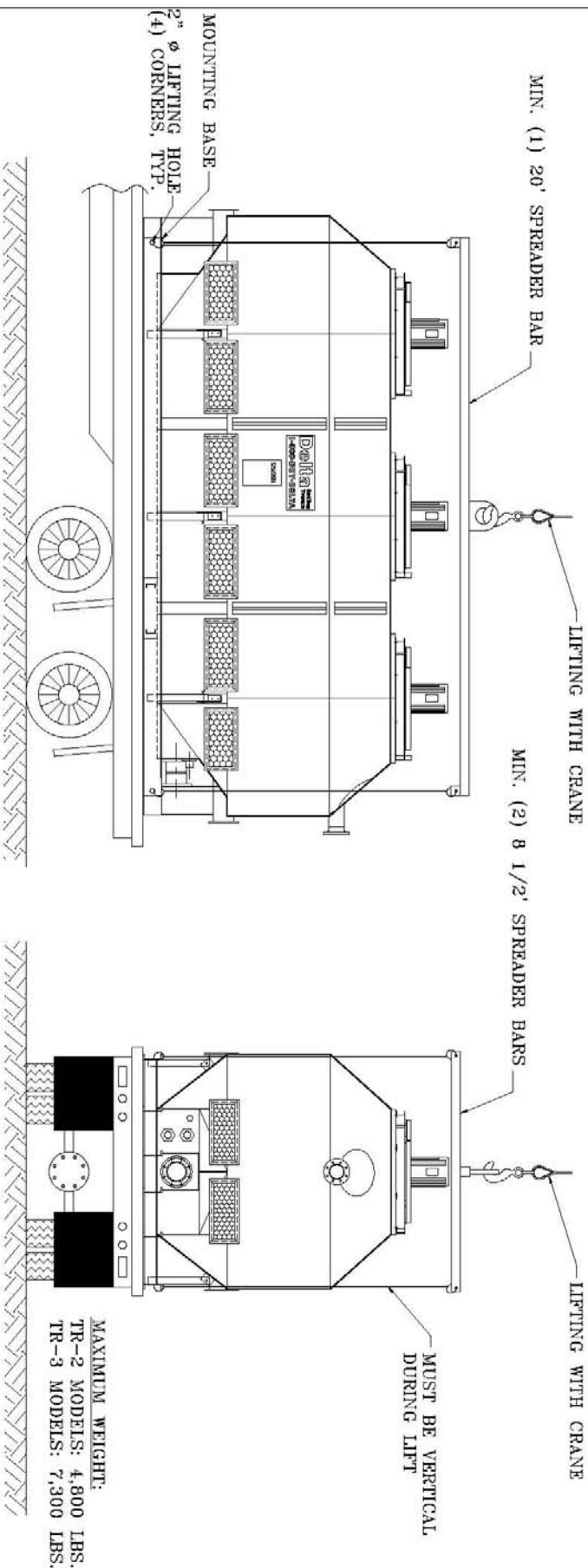

Figure 1 – Off-Loading with a Crane

On-Site Inspection

Upon arrival at the job site, carefully inspect the shipment of any dry damage. If shipping damage has occurred, notify the driver or the carrier immediately in writing of all damage. Check that all items listed on the Shipping Bill of Lading have been received.

Off-Loading

The Premier cooling towers are normally delivered on site on a "30 in. high single drop deck" trailer. The tower assembly is shipped with the steel mounting base strapped to the truck bed. The fan assembly with the motor is normally shipped attached to the tower. Unload the tower assembly complete with mounting base by lifting as shown in Figure 1.

IMPORTANT NOTE:

LIFTING STRAPS OR CHAINS MUST NOT COME IN CONTACT WITH THE TOWER SHELL OR DAMAGE TO THE SHELL IS LIKELY TO OCCUR.

MAXIMUM WEIGHT:
 TR-2 MODELS: 4,800 LBS.
 TR-3 MODELS: 7,300 LBS.

ANY LIFTING METHOD OTHER THAN THE ONE DETAILED ABOVE WILL VOID ALL TOWER WARRANTIES

HANDLING AND INSTALLATION OF YOUR PREMIER™ COOLING TOWER

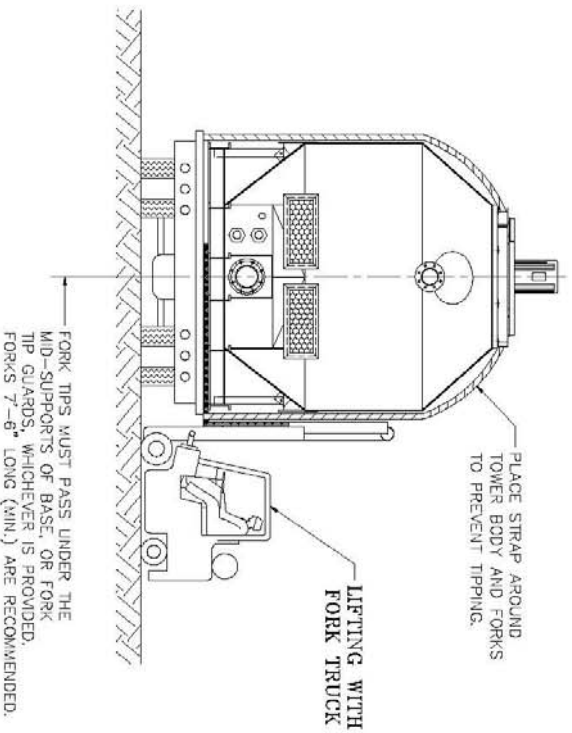

Figure 2 – Off-Loading with a Fork Truck

MAXIMUM WEIGHT:
TR-2 MODELS: 4,800 LBS.
TR-3 MODELS: 7,300 LBS.

On-Site Inspection

Upon arrival at the job site, carefully inspect the shipment of any any damage. If shipping damage has occurred, notify the driver or the carrier immediately in writing of all damage. Check that all items listed on the Shipping Bill of Lading have been received.

Off-Loading

The Premier cooling towers are normally delivered on site on a "30 in. high single drop deck" trailer. The tower assembly is shipped with the steel mounting base strapped to the truck bed. The fan assembly with the motor is normally shipped attached to the tower. Unload the tower assembly complete with mounting base by lifting as shown in Figure 2.

Tower Internals Precheck

Before piping-up and wiring the tower:

- Check to be sure that all shipping material has been removed from the equipment.
- The towers are fully assembled at the factory; but it is recommended that all joints and attachments be checked over. Tighten or adjust as necessary.
- Check the packing support to ensure that it did not shift during shipping or lifting.

CAUTION: *As described earlier, when stepping on top of fill, distribute body weight by means of two plywood plates.*

Electrical Wiring of Fan Motor and Accessories

- Installation of a vibration cutout switch is recommended. (Refer to tower accessories available).
- All electrical work should be performed only by qualified personnel and in accordance to prevailing electrical codes, practices and safety standards.
- The motor starter should be sized on voltage, nominal horsepower, and maximum full load current. This current value can be found on the nameplate. If the starter cannot accept the maximum full load motor current, the next size should be used.
- Motor heaters should be selected on the basics of maximum full load current and service factors based on the motor nameplate.
- Standard "Cooling Tower Service" motors are supplied with a minimum of a 1.15 Service Factor.
- Optional two speed motors are single winding variable torque.
- Run flexible conduit with some slack from the motor conduit box to terminal box outside the tower where rigid conduit can be used.
- Conduit holding clip screws can be tapped directly into the tower wall. Use maximum 3/8" screws.
- For the typical wiring schematic of fan motor and tower accessories, see Delta dwg. DT -B-78-001, included with these instructions.

Location, Piping and Connections

- Refer to the following drawings included with these instructions for recommended layout and pipe connection information.

Model #	Drawing No.
ΔTR-205812 ΔTR-275812 ΔTR-210812	DT-D-86-930/ DT-D-86-913
ΔTR-305812 ΔTR-375812 ΔTR-310812	DT-D-86-929/ DT-D-86-914

- Piping should be adequately sized in accordance with accepted standard practices.
- Gravity drain to indoor storage sump requires proper head differential and piping design considerations. Allowance must be made for flow, pipe size, piping layout and distance of cooling tower from the indoor storage sump.
- On multiple tower installations, valving and/or pipe sizing should balance pressure drops to provide equal inlet pressures. Equalizing lines can be installed between cooling tower sumps and are available as an option

from the factory. Each tower should be valved separately to allow for flow balancing or isolation from service.

- Prior to start-up check that the PVC locknuts on all bulkhead fittings are properly tightened to prevent nuisance leaks. A chain wrench can be used to check and tighten the locknuts.
- Checks that the SS hexagonal nuts on the inlet and outlet PVC socket flanges are properly tightened to prevent nuisance leaks. While tightening the nuts, do not allow the bolt to rotate. This could damage the rubber seal under the flat washer on the bolt head located inside the cooling tower.
- All supply and return piping must be independently supported.

PVC Solvent Cementing Instructions

The following procedure is recommended for the preparation and cementing of internal and external piping for Delta Cooling Towers:

- Cut ends of pipe square using a handsaw and miter box. Tube cutters with wheels designed for use with PVC are acceptable, providing they do not leave a raised bead on the outside diameter of the pipe.
- Use a chamfering tool or file to put a 10° to 15° chamfer on the end of the pipe. Lightly sand the area to be cemented to remove gloss. Using a clean rag, wipe pipe surface and fitting socket to remove dirt, moisture and grease. Acetone or similar solvent is recommended for cleaning.
- “Check " dry fit" of pipe and fitting by inserting, pipe at least 1/3 of the way into the fitting. Position pipe and fitting to assure alignment. Pipe and fitting should be at same temperature condition.
- Using a clean, natural bristle brush about 1/2 the size of the pipe diameter, apply a primer to the fitting socket. Apply primer with a scrubbing motion until the surface is penetrated. Primer should never be applied with a rag. Repeated applications may be necessary to achieve the desired dissolving action. In the same manner, apply primer to the pipe surface equal to the depth of the fitting socket; making sure the surface is well penetrated. Reapply primer to the fitting socket to make sure it is still wet.
- While both surfaces are still wet with primer, use a clean brush to apply a liberal coat of solvent cement to the male end of the pipe. The amount should be more than sufficient to fill any gap. Next apply a light coat of solvent cement to the inside of the socket, using straight outward strokes to keep excess cement out of the socket.
- While both surfaces are still wet with solvent cement, insert the pipe into the socket with a quarter-turn twisting motion. The pipe must be inserted the full length of the socket. The application of solvent cement to pipe and fitting, and the insertion of the pipe into the fitting, should be completed in less than one minute. If necessary, two persons should apply solvent cement to the pipe and fitting simultaneously.
- Hold the joint together for approximately 30 seconds until both surfaces are firmly gripped. After assembly, a properly made joint will usually show a bead of cement around its entire perimeter. This should be brushed off. It is recommended that the joint be allowed to cure for 24 hours before pressure testing or operation.

Operation and Maintenance of Your Premier™ Cooling Tower

Safety in Operation of the Fan

NEVER operate the fan when the access panel or the entire fan guard is removed.

NEVER remove access manhole cover while fan is in operation.

NEVER operate fan when any work, access, maintenance, trouble-shooting, etc. is being performed on the inside of the fan ring assembly or inside the tower plenum.

- Normally, electrical codes dictate a disconnect box at the cooling tower.
- The handle of the disconnect box **must be locked in the off position and an OSHA DANGER tag (DO NOT OPERATE) must be attached to handle securely.**

Note: Removing fuses from the disconnect box may provide further assurance, but only when done by qualified personnel.

The foregoing precautions apply when any type of internal access to the tower is required, including the following examples:

- Checking, maintenance or replacement of any fan assembly component.
- Checking, maintenance or replacement of the water distribution system inside the tower.
- Cleaning of the fill.
- Any work that necessitates removal of any access door, the fan guard or the manhole cover.

Water Distribution System

Water distribution is accomplished by a low-pressure, non-rotating, spray nozzle system designed to accommodate the specified flow rate.

IMPORTANT:

- The flow rate of the cooling tower must be as close to the design gpm as possible. The water distribution system's spray nozzles are provided for the design flow condition. Under pumping or over-pumping will cause the cooling tower to perform inefficiently.
- Design pressure at the inlet connection must be maintained for proper water distribution. If the pressure is less or greater than the design, proper water dispersion over the internal wet decking will be impaired. If inlet pressure is low, water spray will not cover the entire wet decking surface. This causes channeling of air, and does not make maximum use of the heat transfer media. High inlet pressures will cause the water to over-spray the wet decking media, hit the internal side walls of the tower shell and drop in a vertical flow along the shell walls without the opportunity for water / air contact through the heat exchange media. Excessive high spray pressure may also cause wet decking fatigue and damage.
- The operating inlet pressure should be 4.0 to 5.5 PSI at the tower inlet.
- The maximum operating inlet water temperature should not exceed 140° F unless noted otherwise.

CAUTION:

When stepping on top of the fill, distribute the body weight by means of two plywood plates as described earlier in these instructions.

Fan and Mechanical Drive System and Its Maintenance

Safety

Follow all safety instructions previously discussed.

Motor:

- The standard motor is a totally enclosed motor with extra moisture protection on the windings, Class F insulation, 1.15 minimum service factor, epoxy coating on outside frame, and is specifically designed for cooling tower duty to the exclusive specifications of Delta Cooling Towers.
- Should there be a problem with the motor, which may be covered under our standard warranty, the motor **must only** be inspected and serviced by an authorized agent of Delta Cooling Towers, otherwise the warranty is void.
- If the motor bearings have grease fittings, follow the lubrication recommendations as outlined in instructions from motor manufacturer. The majority of motors **do not require greasing**.

Start-up Instructions

Complete all start-up instructions before applying heat load.

- Clean any accumulated debris or packaging material from inside tower sump.
- Check to be sure that the fan motor is properly wired for correct rotation as viewed from the top of the fan. Reverse leads will cause incorrect rotation and reverse direction of airflow.

Note: Fan rotation should always agree with rotation labels. Standard fan rotation is clockwise, (C.W.) however; non-standard fans may be designed to rotate counter clockwise, (C.C.W.)

- Check for free rotation of the fan and fan blade tip clearance.
- Fill the cooling tower sump or the cold-water storage reservoir on gravity drain applications.
- Water recirculation pump should be primed and all piping below the tower sump filled with water. Check pump for proper shaft rotation.
- Start water recirculation pump and adjust flow to design. A flow-metering device installed in the inlet is recommended but if not available, use the pressure differential across the pump in conjunction with the pump curve.
- Check spray pattern from nozzles to be sure there is no clogging. Remove drift eliminators for nozzle inspection, and then return to proper position.

- Start up fan motor and check amperage and voltage against motor nameplate data.
- The standard make-up valve assembly is shipped with the plastic float ball strapped against the tower side to prevent damage. To set the ball for proper operation, loosen the screw in the fulcrum arm, lift or depress the arm with the plunger pressed against the valve seat and tighten. Repeat until the proper operating level is obtained (Refer to operating level table below). It is recommended that a shut-off valve be installed in the make-up line.
- After 24 hours of operation:
 - ❑ Check spray nozzles for clogging.
 - ❑ Check tower sump water level.

Water Level in Tower Sump

- When the cooling tower is being operated with pump-suction, the make-up valve assembly with float ball should be adjusted to set the water operating level as follows:

Tower Model #	Operating level (from bottom of sump)
All Towers	Between 10-12 inches

Access the make-up valve through the access louver panel.

- A lower water level than recommended may cause air to be drawn into the tower outlet piping and cause pump "cavitation."
- A water level higher than recommended will cause continuous overflow and waste of water as a result of potential "pull-down" from the piping when the system is shut down.
- The overflow should **NEVER** be capped, or its elevation altered by raising external piping.

Note: On gravity drain cooling tower(s), make-up assembly, overflow, drain and vortex breaker are not provided.

Cold Weather Operation

Cold Weather Protection

The cooling tower may require protection against freezing at light heat loads when the wet-bulb temperature is under 32°F., or during shutdown when the temperature drops below 32°F.

The following methods are recommended for use in Delta Cooling towers for protection during cold weather conditions. Recommended equipment is optional and may be ordered from the factory. Consult the factory for further information on which equipment to choose for your specific application.

Separate Indoor Sump

This method is virtually foolproof antifreeze protection system with the added advantage of minimum maintenance. The indoor sump tank should be large enough to fill the entire recirculation system without danger of pump cavitation. As a general rule, the tank should be sized to hold three times the rate of circulation in gallons per minute (gpm).

The tank should be provided with properly sized overflow, make-up drain and suction connections. When a separate sump is ordered with a cooling tower, the water make-up valve assembly and the overflow and drain connections are installed in the indoor sump only.

When a sump tank is used, the cooling tower should be located high enough above it to allow free cold-water gravity drain. A bottom outlet can be provided for gravity drain to indoor sump tank installations.

Reverse siphoning is a back flow of non-potable, recirculating water into a potable water system, which can occur through the make-up float valve assembly located in the water reservoir. Should the valve malfunction, blockage of the overflow or outlet lines would cause water level to rise in the reservoir, and the make-up water pressure could drop below the atmospheric pressure creating a vacuum at the make-up inlet. Although precautions to prevent reverse siphoning are incorporated in the cooling tower design, we also recommend installing a check valve in the water make-up supply line, as a backup precaution.

Electric Immersion Heater

Cooling towers ordered with antifreeze systems are shipped with a protective seat secured under the immersion heater probe, which must remain in place during operation to protect the polyethylene shell from the heater element.

*Note: This seat is not a shipping brace and **must not be removed.***

Thermostatic On/Off Control

A thermostatically controlled fan for on/off operation should be considered as an energy saving feature, for capacity control during winter operation. The thermostatic control can be field set to insure automatic fan shut-down when cold water drops below design temperatures, as well as fan start-up when cold water rises to design temperature.

A thermostatic control provides excellent cooling tower anti-freeze protection while reducing operating costs throughout cold weather operation.

PVC Distribution System

To prevent damage to the PVC distribution system during cold weather shutdown, install an automatic or manual drain line from the hot water inlet piping as close to the cooling tower inlet as possible. The entire inlet and distribution system must be drained for shutdown in sub-freezing weather.

Piping

When the cooling tower is located outdoors, adequate measures including the use of heating tapes and insulation should be considered to protect water lines from freezing.

Operation at Sub-freezing Ambients

See Thermostatic On/Off control

To prevent ice formation, insure that tower operates at maximum possible heat load.

If tower is equipped with two speed motors, operate at low speed to increase leaving water temperature.

On multi-cell installations, it may also be necessary to cycle fan(s) periodically to prevent ice formation on the intake louvers and the wet decking. If fan(s) are operated in reverse, **DO NOT** operate in reverse any longer than is necessary. Extended reverse operation can cause ice to form on the fan blades causing an out-of-balance condition. **A vibration cutout switch is always recommended.**

The importance of frequent visual inspections and routine maintenance during sub-freezing operation is very important and should not be overlooked.

Trouble-Shooting Guide For Premier™ Induced Draft Cooling Towers

Problem	Possible Causes	Corrective Actions
Increase in the leaving water temperature	<ol style="list-style-type: none"> 1. Excess water flow; over pumping. 2. Recirculation of hot discharge air, back into the cooling tower air intakes. Obstructed air intakes 3. Proximity of other heat source or discharge of moist air. 4. Improper operation of spray system. <ol style="list-style-type: none"> A. Orifices clogged. B. Actual water flow is lower than design sprinkler rating. 5. Clogged fill. 6. Damaged fill. 7. Additional heat load on system. 8. Wet-bulb temperature higher than design. 	<ol style="list-style-type: none"> 1. Adjust to the design flow. 2. Eliminate obstructions that impede air discharge. For proper location of cooling tower(s), see Delta dwgs. Baffle air discharge, if necessary. 3. Remove source or relocate tower. 4. See water distribution system instructions. <ol style="list-style-type: none"> A. Flush spray nozzles, clean orifices, clean system, install outlet strainer. B. Install properly rated spray nozzles or increase to design flow. 5. Clean the fill. 6. Replace the fill. 7. Contact Delta for possible upgrade or addition of another cooling tower selected for additional load. 8. None required if condition is temporary. Otherwise consult Factory for upgrade.
Drop in the water flow rate. Low water flow rate	<ol style="list-style-type: none"> 1. Blockage of spray nozzle orifices. 2. Low water level in sump causing air to be drawn into pump and piping. 3. Improper selection of water circulating pump. 4. Blockage of strainers. 5. Pump malfunction. 	<ol style="list-style-type: none"> 1. Flush spray nozzle. Clean whole system. Install outlet strainer. 2. Adjust float valves. Be sure the system is flooded and balanced. 3. Replace with proper size pump designed for flow and head requirements. Check pump "Net positive suction head." 4. Backwash or clean. 5. Consult pump specialist.
Noise and vibration	<ol style="list-style-type: none"> 1. Loose bolts. 2. Mechanical interference of rotating parts. 3. Fan propeller damaged or out of balance. 4. Air intake at pump. 5. Pump cavitations. 6. Damaged motor bearings. 	<ol style="list-style-type: none"> 1. Recheck and tighten all bolts to specified torque. 2. Inspect propeller for free rotation. Check propeller for mechanical interference. Adjust, repair or replace, as necessary. 3. Replace components, as necessary and check balance. Install vibration cutout switch. 4. Check basin water level and irregular piping design. 5. Match pump NPSH with system hydraulics. 6. Check and replace motor.
Sudden or short term irregularities of cold water level in basin	<ol style="list-style-type: none"> 1. Peculiarities of specific system and its operation. 	<ol style="list-style-type: none"> 1. Inspect system and review operation procedures. Correct, as applicable valve settings, loss of water in system, fill system to flooded capacity.
Excessively high water level in sump on gravity drain installation	<ol style="list-style-type: none"> 1. Gravity flow restrictions due to insufficient head differential. 	<ol style="list-style-type: none"> 1. <ol style="list-style-type: none"> A. Outlet piping should terminate below sump tank water level. B. Increase discharge pipe size. C. Increase head by mean other than A.

Problem	Possible Causes	Corrective Actions
	<ol style="list-style-type: none"> 2. Airlock. 3. Unnecessary obstruction of water flow (i.e., partially closed valve). 4. Undersized piping. 5. Horizontal pipe run too long. 6. Improper hydraulic pipe design. 7. Outlet vortex breaker provided. 	<ol style="list-style-type: none"> 2. Install an air bleed valve at highest point of piping, usually at a vertical angle. 3. Remove obstruction. 4. Increase pipe size. 5. Shorten, if possible. 6. Correct design. 7. Remove vortex breaker.
Excessively high water level in tower basin on closed loop system installations	<ol style="list-style-type: none"> 1. Make-up valve float set too high. 2. Valve or float damaged or malfunctioning. 3. Make-up water pressure too high. 	<ol style="list-style-type: none"> 1. Readjust float arm. 2. Repair or replace. 3. Reduce pressure or contact Delta for alternate solutions.
Uneven water level in tower basins of multi-cell installations	<ol style="list-style-type: none"> 1. Unbalanced system hydraulics. 2. More than one make-up valve operating, and set for different water levels. 	<ol style="list-style-type: none"> 1. <ol style="list-style-type: none"> A. Install equalizer line with isolation valves between modules. B. Adjust inlet water flow to insure equal distribution to each cooling tower module. C. Review outlet header hydraulics and correct piping design, if applicable. D. Contact Delta for assistance. 2. <ol style="list-style-type: none"> A. Adjust float level settings relative to one another. B. Shut-off and or/throttle flow to one or more valves. C. Installation of equalizers is highly recommended.
Excessive water carry over (drift)	<ol style="list-style-type: none"> 1. Surfaces of top layer of fill damaged causing "pooling" of water. 2. Eliminator(s) not in place. 3. Damaged eliminator. 4. Excess water flow. 5. Orifices in spray nozzles clogged causing improper water dispersement. 6. Blockage of fill. 	<ol style="list-style-type: none"> 1. Replace top layer. Protect fill when working inside tower. 2. Reinstall. 3. Replace. 4. Reduce water flow or install spray nozzles designed for the actual operating flow. 5. Install outlet strainer. Clean whole system and spray nozzles. 6. Clean fill.
Premature or excessive corrosion of fan drive components	<ol style="list-style-type: none"> 1. Excessive drift. 2. Presence of corrosive chemicals in air or water that was not known at time of supply. 	<ol style="list-style-type: none"> 1. See "Excessive Water Carry Over (Drift)" above. 2. Remove source of corrosion or contact Delta for alternative materials, premium coatings or other precautions.

Motor Trouble Shooting Guide (General)

Problem	Possible Causes	Corrective Actions
High current draw (all 3 phases)	<ol style="list-style-type: none"> 1. Low line voltage (5 to 10% lower than nameplate). 2. 200V motor on 230/240V system. 3. 230V motor on 208V system. 4. Incorrect propeller. 5. Incorrect pitch if adjustable 	<ol style="list-style-type: none"> 1. Consult Power Company. 2. Change to 230V motor. 3. Change to 200V or 280V motor. 4. Consult factory. 5. Reduce pitch / consult factory
Low motor current draw	<ol style="list-style-type: none"> 1. Incorrect propeller. 2. Incorrect pitch if adjustable. 	<ol style="list-style-type: none"> 1. Consult factory 2. Increase pitch / consult factory
Unbalanced current (5% from average)	<ol style="list-style-type: none"> 1. Unbalanced line voltage due to: <ol style="list-style-type: none"> A. Power supply. B. Unbalance system loading. C. High resistance connection. D. Undersized supply lines. 2. Defective Motor. 	<ol style="list-style-type: none"> 1. Consult Power Company and/or electrician. 2. Replace motor.
Excessive voltage drop (2 or 3% of supply voltage)	<ol style="list-style-type: none"> 1. Inadequate power supply. 2. Undersized supply lines. 3. High resistance connections. 	<ol style="list-style-type: none"> 1. Consult Power Company. 2. Increase line sizes. 3. Check motor leads and other connections.
Overload relays tripping	<ol style="list-style-type: none"> 1. Overload. 2. Unbalanced input current. 3. Single phasing. 4. Excessive voltage drop. 5. Frequent starting or intermittent overloading. 6. High ambient starter temperature. 7. Wrong size relays. 8. Improper overload settings of adjustable relays. 	<ol style="list-style-type: none"> 1. Reduce load on motor or increase motor size. 2. Balance supply voltage. 3. Eliminate. 4. Eliminate (see above). 5. Reduce frequency of starting and overloading or increase motor size. 6. Reduce ambient temperature. 7. Correct size per nameplate current and service factor. 8. Readjust to motor FL Amps x S.F.
Motor runs very hot	<ol style="list-style-type: none"> 1. Overloaded. 2. Blocked ventilation. 3. High ambient temperature. 4. Unbalanced input current. 5. Single phased. 	<ol style="list-style-type: none"> 1. Reduce overload. 2. Fouled fill or air restriction. 3. Reduce ambient temperature. 4. Balanced supply voltage. 5. Eliminate.
Motor will not start	<ol style="list-style-type: none"> 1. Single phased. 2. Rotor or bearings locked. 	<ol style="list-style-type: none"> 1. Shut power off – eliminate. 2. Shut power off – check shaft rotation.
Excessive vibration (Mechanical)	<p>Out of balance</p> <ol style="list-style-type: none"> 1. Motor mounting. 2. Motor. 	<ol style="list-style-type: none"> 1. Check to be sure motor mounting hardware is tight. 2. Replace motor.

Note: Consult Warranty page prior to replacing or repairing any cooling tower components. Delta recommendation and consent to remedy material and workmanship defects is necessary, to avoid breach of Warranty.

Premier™ Optional Accessories

Premier™ Optional Accessories Available

- ❑ Aluminum Ladder(s) with a step platform and railing at the fan elevation **custom designed** for the cooling tower.
- ❑ Safety cage(s).
- ❑ Two speed motor(s) designed for cooling tower duty to the exclusive specifications of Delta Cooling Towers.
- ❑ Vibration cutout switch provides for fan motor circuit disconnect for shutdown protection should abnormal fan vibration develop during service. Installations of vibration cutout switches are **recommended** as good design practice.
- ❑ Thermostat on/off control of fan operation through sensing the temperature of water leaving the tower.
- ❑ Basin anti-freeze system for cold weather operation.
- ❑ **Custom designed** top platform with handrails.
- ❑ Pre-wired control panels.
- ❑ Elevated mounting frame structures.
- ❑ Pumps
- ❑ Polyethylene Sump tanks up to 10,000 gallons for indoor installation for anti-freeze protection during winter operation.
- ❑ Motor space heaters are recommended for unusually high relative humidity conditions where extreme day to night temperatures can cause excessive condensation in the motor, when in operation during this period.
- ❑ Plastic outlet sump strainer.
- ❑ Plastic equalizer fittings.
- ❑ Variable frequency drive on fan motors, controlled by temperature controller.
- ❑ High sump level switch
- ❑ Automatic drain valve

Consult factory or a Delta representative for further information and an updated list of accessories.

Premier™ Recommended Replacement Parts

To avoid costly cooling tower downtime, the following replacement parts should be carried in inventory at the installation site:

- ❑ Make-up floats, or complete make-up valve assembly.
- ❑ Fan Motor.
- ❑ Complete set of spare spray nozzles.

When ordering, include model number and serial number of the cooling tower as it appears on the tower nameplate. Under normal conditions, shipment of factory replacement parts is made within one day after the order is received. Spare pumps and pump parts, as well as control panel components, such as fuses and heaters for magnetic starters, are also available.

Preventative Maintenance Checklist

Procedure	Monthly	Every 3 Months	Every 6 months
Inspect General Condition of cooling tower.	✓		
Check Water Level in cold-water basin. Adjust if needed.	✓		
Check float ball & Make-up Valve for proper operation.	✓		
Check Line Voltage, Motor Amperage, and Water Pressure.	✓		
Clean Sump Strainers , if installed.	✓		
Lubricate Motor Bearing, (if motor has fittings for greasing. The majority of motors require no external greasing). Use Proper Lubricants . Increase frequency, as necessary depending on conditions of service.		✓	
Check for obstructed Water Flow Through Orifices . Clean and flush sprinkler lateral arms, as required.		✓	
Check All Bolts , which can cause unbalance and vibration and tighten, specified torque.		✓	
Check Condition of Water for proper treatment to prevent build-up of algae and solids concentration		✓	
Clean and flush Cold Water Sump			✓

1. **Sale Not a Consumer Transaction:** Buyer agrees that the purchase of Delta's Products (hereinafter "Product") is not for consumer, household or family purposes.
2. **Agreement of Sale: Acceptance:** Any acceptance contained herein is expressly made conditional on Buyer's assent to any terms contained herein that are additional to or different from those proposed by Buyer in its purchase order and hence any terms and provisions of Buyer's purchase order which are inconsistent with the terms and conditions hereof shall not be binding on the Seller. Unless Buyer shall notify Seller in writing to the contrary as soon as practicable after receipt hereof, acceptance of the terms and conditions hereof by Buyer shall be deemed made and, in the absence of such notification the sale and shipment by the Seller of the goods covered hereby shall be conclusively deemed to be subject to the terms and conditions hereof.
3. **Entire Contract:** This contract constitutes the final and entire agreement between Seller and Buyer and any prior or contemporaneous understandings or agreements, oral or written are merged herein. The sales and technical representatives of the Seller are not authorized to make warranties about the product. Sellers representatives' oral statements do not constitute warranties, shall not be relied upon by the Buyer, and are not part of the contract for sale. Any product-literature and operating instructions, and statements contained therein, do not constitute warranties, shall not be relied upon by the Buyer and are not part of the contract for sale. The entire contract is embodied in this writing and no other warranties are given beyond those set forth in this contract. This writing constitutes the final written expression of the parties agreement, and it is a complete an exclusive statement of the terms of the agreement.
4. **Prices:** Except where expressly agreed, all prices are subject to change without notice. If there is a delay in approval of drawings related to this contract beyond 30 days, an escalation in selling price may occur due to a rise in labor and/or material prices.
5. **Taxes:** The price of goods does not include sales, use, excise, ad valorem, property or other taxes now or hereinafter imposed, directly or indirectly by any governmental authority or agency with respect to the manufacture, production, sale, delivery, consumption or use of goods covered by this contract. Buyer shall pay such taxes directly or reimburse Seller for any such taxes which it may be required to pay.
6. **Payment:** The specific terms of payment are as specified in writing by Seller. If the Buyer shall fail to make any payments in accordance with the terms and provisions hereof, the Seller, in addition to its other rights and remedies, but not in limitation thereof, may, at its option, defer shipments or deliveries hereunder, or under any other contract with the Buyer, except upon receipt of satisfactory security or of cash before shipment.
7. **Shipment; Risk of Loss Title:** The goods shall be shipped FOB Seller's shipping points. Risk of loss shall pass to Buyer upon delivery to the carrier. Title shall pass to Buyer on delivery to the carrier.
8. **Delivery; Delays in Deliveries:** The date of delivery provided herein is an approximation based on Seller's best judgement. Seller shall be excused for delay in delivery, may suspend performance and shall under no circumstances be responsible for failure to fill any orders when due to acts of God or of the public enemy; fires; floods; riots; strikes; freight embargos or transportation delays; shortage of labor; inability to secure fuel; material supplies, or power at current prices or on account of shortages thereof; any existing or future laws or acts of the Federal or of any State Government (including specifically, but not exclusively, any orders, rules or regulations issued by any official or agency of any such government).
9. **LIMITED WARRANTY:** Seller warrants that the cylindrical, seamless molded polyethylene shell of the Product shall be free from defects in materials and workmanship and will not peel, chip, rust or need painting for a period of fifteen (15) years from the date of shipment. Since the Product once in operation is under the sole control of the User, this warranty is further subject to and shall be applicable only if all of the following conditions are met:
 - a. The Product has been properly erected in accordance with the Seller's instructions and in accordance with good installation practices;
 - b. Seller's instructions and recommendations as to operation and maintenance have been followed, including those contained in the manual furnished with the Product;
 - c. The Product has been used under normal operating conditions;
 - d. The Product has not been affected by misuse, neglect, accident or abrasion;
 - e. The User has not attempted or performed corrective work on the Product without Seller's prior written consent; and
 - f. The Seller shall have received notice of any defect no later than 10 days after User first has knowledge of same.Except where expressly noted otherwise, Seller warrants all Product components, other than moving parts, against defects in workmanship and material for a period of one (1) year from the date of shipment, provided the equipment has been properly maintained and operated under normal conditions. Motors and blowers carry a normal manufacturer's one (1) year warranty against defects in workmanship and materials beginning from the date of shipment and subject to the same conditions of proper use and operation as other components of the Product. Bearings, pulleys, belts or other moving parts and components are sold without any warranty.
10. **DISCLAIMER OF ALL OTHER WARRANTIES AND GUARANTEES:** The aforesaid warranty is the sole and only warranty or guarantee relating to the product provided under this Agreement, and is in substitution for, and in lieu of, any and all other warranties, written or oral, expressed, implied or statutory including any warranty of merchantability or of fitness for a particular purpose.
11. **CORRECTION OF DEFECTS AS SOLE REMEDY:** If the Buyer/User gives the Seller written notice of defects in the product within any period of warranty described herein and the Seller's inspection confirms the existence of such defect, the Seller, at its option, shall correct the defect or defects either by repair, providing repair tools and instructions, or replacement, FOB Seller's shipping point, or refund the purchase price of the product. The remedies provided Buyer/User herein for breach of Seller's warranty shall be exclusive. No expense, liability or responsibility will be assumed by the Seller for repairs made by other than Seller's agent without written authority from the Seller. Remedial action, in the manner and for the period of time provided above, shall constitute fulfillment of all liabilities of Seller to the Buyer / User, and Buyer/User's sole remedy hereunder, whether based on contract, tort or otherwise. The sole purpose of stipulated exclusive remedy shall be to provide the User with free repair and replacement of defective parts in the manner provided herein. This exclusive remedy shall not be deemed to have failed of its essential purpose so long as the Seller is willing and able to repair or replace defective parts in the prescribed manner. An action for breach of this limited warranty or any other action otherwise arising out of this contract must be commenced within one (1) year from the date the right, claim, demand or cause of action shall first occur, or be barred forever.
12. **STATEMENT OF BUYER/USER'S RESPONSIBILITIES:** It is the sole responsibility of the Buyer/User, and not in any manner the responsibility of the Seller, to test, control and properly dispose of all discharges, both gaseous and liquid, from the product to assure:
 - a. Compliance with all federal, state and municipal (or any political subdivision thereof) statutes, laws, codes, ordinances, rules and regulations concerning the environment, including but not limited to: The Clean Air Act, 42 U.S.C. S7401 *et seq.*; The Clean Water Act, 33 U.S.C. S1251 *et seq.*; The Comprehensive Environmental Response, Compensation and Liability Act, 42 U.S.C. S9601 *et seq.*; The Toxic Substance Control Act, 15 U.S.C. S2601 *et seq.*; The Resource Conservation and Recovery Act, 42 U.S.C. S6901 *et seq.*; The Safe Drinking Water Act, 21 U.S.C. S349 *et seq.*; The National Environmental Policy Act, 42 U.S.C. S4321 *et seq.*; Occupational Safety and Health Act, 29 U.S.C. S651 *et seq.*; together with any amendments thereto and regulations promulgated thereunder;
 - b. Adequate protection for the health and safety of people, property, wildlife and environment; and
 - c. Adequate protection for all persons, including employees, coming in contact with the Product and its discharges for all purposes including, without limitation, installation, maintenance, use and repair of the Product.

It is also the sole responsibility of the Buyer/User to:
 - d. Maintain the Product in accordance with the "Installation, Operating and Maintenance Instructions";
 - e. Comply with the maintenance checklist contained in the "Installation, Operating and Maintenance Instructions"; and
 - f. Periodically monitor and test the Product to verify proper functioning, and to insure the Product performs properly.It is further the sole responsibility of the Buyer/User to comply with all laws, codes, and regulations relating to the Product and its use and Seller makes no warranty or representation with respect thereto. Buyer/User assumes the responsibility for providing and installing all devices required to protect the health and safety of people, property, wildlife and the environment. Buyer/User acknowledges having read the "Installation, Operating and Maintenance Instructions", including all warnings contained therein, and is aware of the precautions recommended for protection to the health and safety of people, property, wildlife, and the environment, including employees coming in contact with the Product discharges. Buyer/User assumes full responsibility to assure proper use of the Product, including the determination and control of what chemicals, pollutants and toxic substances are introduced into the product, and the determination and control of all discharges from the Product.
13. **DISCLAIMER OF TORT, CONTRACT, STATUTORY AND ALL OTHER LIABILITY:** The Seller hereby disclaims all tort, contract or statutory liability to the Buyer/User, and any other basis of liability to Buyer/User regarding claims for injury or damage to people, property, wildlife, or the environment, including, without limitation, claims of negligence, strict product's liability, breach of warranty (except the limited warranties as provided in paragraph 9 entitled: "Limited Warranty"), breach of contract or violation of statute, law, ordinance, code, rule or regulation. Seller also disclaims any liability to the Buyer/User in contribution or indemnification for the Buyer/User's liability or alleged liability to any third person or entity for injury or damage to people, property, wildlife or the environment. Without limiting the generality of the foregoing, Seller disclaims liability for all claims for compensatory, consequential, incidental or other damages and for damages for personal injury and property damage, loss of use, revenue or profit, injury to good will, inability to fulfill contracts to third parties, other economic loss, response costs and other environmental clean-up costs or other damages arising out of the actual, alleged or threatened discharge, dispersal, release or escape of pollutants, contaminants, hazardous waste, or liquid or gaseous materials discharged from or through the Product and any loss, cost or expense arising out of any governmental or other direction or request to test for, monitor, clean-up, remove, contain, treat, detoxify or neutralize the foregoing. Seller also disclaims liability for all claims for damages arising from the actual or alleged violation of any federal, state, municipal (or political subdivision thereof) statute, law, ordinance, code, rule or regulation relating to the environment, including but not limited to: The Clean Air Act, 42 U.S.C. S7401 *et seq.*; The Clean Water Act, 33 U.S.C. S1251 *et seq.*; The Comprehensive Environmental Response, Compensation and Liability Act, 42 U.S.C. S9601 *et seq.*; The Toxic Substances Control Act, 15 U.S.C. S2601 *et seq.*; The Resource Conservation and Recovery Act, 42 U.S.C. S6901 *et seq.*; The Safe Drinking Water Act, 21 U.S.C. S349 *et seq.*; The National Environmental Policy Act, 42 U.S.C. S4321 *et seq.*; Occupational Safety and Health Act, 29 U.S.C. S651 *et seq.*; together with any amendments thereto and regulations promulgated there under. Seller further disclaims any liability, direct or indirect, resulting from the Buyer/User's failure to fulfill the responsibilities enumerated in the preceding paragraph entitled "Statement of Buyer/User's Responsibility" including without limitation:
 - a. Buyer/User's failure to comply with statutes, laws, codes, rules and regulations relating to the Product and the environment; and
 - b. Buyer/User's failure to provide and install all devices required for the protection of the safety and health of people, property, wildlife and the environment and all persons, including employees of the User

- coming in contact with the Product and its discharges; and
- c. Buyer/User's failure to adhere to the "Installation, Operating and Maintenance Instructions" and the product literature, including all warning contained therein;
 - d. Buyer/User's failure to test and monitor the functioning of the Product; and
 - e. Buyer/User's failure to determine and control the safety and cleanliness of discharged effluents, both gaseous and liquid, from the Product.
14. **EXCULPATORY AND INDEMNIFICATION AGREEMENT:** Buyer/User hereby agrees that the Seller will not be liable to the Buyer/User for the matters referred in paragraph 13 entitled "Disclaimer of Tort, Contract, Statutory and All Other Liability." This exculpatory agreement applies even if the defect and/or loss, damage or injury to persons, property, wildlife and the environment resulted solely or in part from the Seller's actuator alleged negligence, breach of warranty, violation an statute, law, ordinance, rule or regulation, or actions resulting in strict liability.
- The Buyer/User hereby agrees to defend, hold harmless and indemnify the Seller and Seller's agents from and against all claims, suits, actions, and liabilities for injury or damage to people, property, wildlife, or the environment, including, without limitation, claims of negligence, strict products liability, breach of warranty (except the limited warranties provided in paragraph 9 entitled "Limited Warranty"), breach of contract or violation of statute, law, ordinance, code, rule or regulation.
- The Buyer/User hereby agrees to defend, hold harmless and indemnify the Seller and Seller's agents from and against all claims, suits, and actions including claims for contribution or indemnification for another's liability or alleged liability to any third person or entity for injury or damage to people, property, wildlife or the environment.
- Without limiting the generality of the foregoing, the Buyer/User hereby agrees to defend, hold harmless and indemnify the Seller and Seller's agents from and against all claims, suits, actions, and liabilities for compensatory, consequential, incidental or other damages and for damages for personal injury and property damage, loss of use, revenue or profit, injury to good will, inability to fulfill contracts to third parties, other economics loss, response costs and other environmental clean-up cost or other damages arising out of the actual, alleged or threatened discharge, dispersal, release or escape of pollutants, contaminants, hazardous waste, or liquid or gaseous materials discharged from or through the Product and any loss, cost or expense arising out of any governmental or other direction or request to test for, monitor, clean-up, remove, contain, treat, detoxify or neutralize the foregoing.
- The Buyer/User hereby agrees to defend, hold harmless and indemnify the Seller and Seller's agents from and against all claims, suits, actions, and liabilities for damages arising from the actual or alleged violation of any federal, state, municipal (or political subdivision thereof) statute, law, ordinance, code, rule or regulation relating to the environment, including but not limited to: The Clean Air Act, 42 U.S.C. S7401 *et seq.*; The Clean Water Act, 33 U.S.C. S1251 *et seq.*; The Comprehensive Environmental Response, Compensation and Liability Act, 42 U.S.C. S9601 *et seq.*; The Toxic Substances Control Act, 15 U.S.C. S2601 *et seq.*; The Resource Conservation and Recovery Act, 42 U.S.C. S6901 *et seq.*; The Safe Drinking Water Act, 21 U.S.C. S349 *et seq.*; The National Environment Policy Act, 42 U.S.C. S4321 *et seq.*; Occupational Safety and Health Act, 29 U.S.C. S651 *et seq.*; together with any amendments thereto and regulations promulgated there under.
- The Buyer/User hereby agrees to defend, hold harmless and indemnify the Seller and Seller's agents from and against all claims, suits, actions, and liabilities, direct or indirect, resulting from the Buyer/User's failure to fulfill the responsibilities enumerated above in number 12 entitled "Statement of Buyer/User's Responsibilities" as if the Buyer were the User as referred to therein, including without limitation:
- a. Buyer/User's failure to comply with statutes, laws, codes, rules and regulations relating to the Product and the environment; and
 - b. Buyer/User's failure to provide and install all devices required for the protection of the safety and health of people, property, wildlife and the environment and all persons, including employees of the User coming in contact with the Product and its discharges; and
 - c. Buyer/User's failure to adhere to the "Installation, Operating and Maintenance Instructions" and the product literature, including all warning contained therein;
 - d. Buyer/User's failure to test and monitor the functioning of the Product; and
 - e. Buyer/User's failure to determine and control the safety and cleanliness of discharged effluents, both gaseous and liquid, from the Product.
- The Buyer/User hereby agrees to defend, hold harmless and indemnify the Seller and Seller's agents from and against all claims, suits, actions, and liabilities as enumerated above without limitation even if said claims, suits, actions, and liabilities are based upon actual or alleged negligence, breach of warranty (other than the limited warranty provided in paragraph 9 entitled: "Limited Warranty"), violation of any law, statute, ordinance, rule or regulation, or any other basis of liability on the part of Seller or Seller's agents.
15. **Assignment:** No right or interest in this contract shall be assigned by Buyer/User without prior written agreement by the Seller. No delegation of any obligation by the Buyer/User shall be made without prior written agreement by the Seller.
16. **Modifications; waiver:** No Waiver, alteration or modification of any of the provisions hereof shall be binding on the Seller unless made in writing and agreed to by a duly authorized official of the Seller. No waiver by the Seller of any one or more defaults by the Buyer/User in the performance of any provision of this contract shall perate or be construed as a waiver of any future default or defaults whether of a like or of a different character.
17. **Changes & Improvements:** Seller reserves the right to make changes, and improvements in its Products at any time without notice. Where such change and improvements have been made, Seller shall not be obligated to incorporate such changes and improvements in Products previously sold to any customer, nor shall Seller be obligated to replace previously sold products with products incorporating such changes and improvements.
18. **Return of Goods:** Where Seller has provided prior written authorization, Seller will accept the return for credit or exchange of products which have been made to the specifications set forth in its catalogs and other literature, provided the product has not been altered or damaged. Products returned for credit will be subject to a 20% restocking charge. Return products must be shipped prepaid to Seller at the location noted in written authorization.
19. **Technical Services:** Upon request of Buyer/User, Seller will endeavor to furnish such technical advice as it has available in reference to the use of its products. Any technical advise furnished by Seller with reference to the use of its products is given and accepted at Buyer/User's risk and the Seller assumes no obligation or liability for the advice given or results obtained.
20. **APPLICABLE LAW:** The validity, interpretation and performance of all terms, conditions, warranties, disclaimers, indemnification and exculpatory provisions, and all other provisions described herein, and any purchase or sale made hereunder shall be governed by the law of New Jersey in force at the date this contract is made. Where not modified by the terms herein, the provision of Article 2 of the Uniform Commercial Code as enacted by the State of New Jersey shall apply to this transaction.
21. **SEVERABILITY:** If any provision or clause of this contract or application thereof to any person or circumstances is held invalid or unconscionable such invalidity or unconscionability shall not affect other provisions or applications of the contract which can be given effect without the invalid or unconscionable provision or application, and to this end the provisions of the contract are declared to be severable.
22. **WAIVER:** If the Seller, at its option, agrees to a waiver of any of the terms and conditions recited herein, such waiver shall not for any purpose be construed as a waiver of any succeeding breach of the same or any other terms or conditions of said contract; nor shall such a waiver be viewed as a course of performance.
23. **BUYER/USER'S ACKNOWLEDGMENT:** User/Buyer acknowledges that he has read both sides of this contract and accepts its terms.