

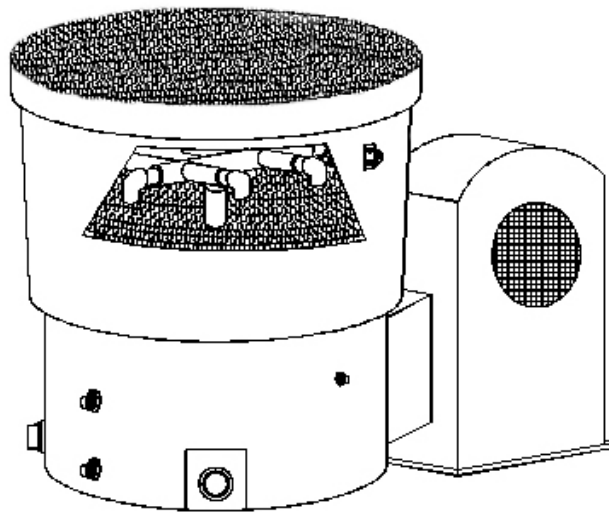

# Delta Cooling Towers, Inc.

---

## *Pioneer<sup>®</sup> Forced Draft Cooling Towers*



## **Installation, Operation and Maintenance Manual**

---

# Table of Contents

---

<b>Delta Cooling Towers</b>	Principle of Cooling Towers.....1
	Cooling Tower Terms & Definitions.....1
<b>Installation</b>	Safety Procedures..... 2
	Location of the Cooling Tower..... 2
	Hoisting..... 2
	Cooling Tower Installation.....2
	Cold Weather Protection.....3
	Piping and Tower Connections..... 4
	Duct to Blower Housing Installation.....4
	PVC Solvent Cementing Instructions..... 5
<b>Operation</b>	V-Belt Alignment and Tensioning.....5
	Initial Start-up.....5
	Operating Design Condition Checklist.....6
<b>Maintenance</b>	Water Treatment..... 6
	Disassembly and Cleaning.....7
	Preventative Maintenance Checklist.....8
	Recommended Replacement Parts.....8

---

**Important:** Delta's cooling towers have been designed to provide trouble-free service over an extended period of time. To obtain the design performance, it is necessary that the cooling tower be installed, operated and maintained as prescribed in these instructions.

Only persons possessing the skill and experience described herein should attempt to install this equipment. Prior to installation, these instructions should be read carefully by the person who is to install the cooling tower to be certain that its installation, operation and maintenance are thoroughly understood.

Questions regarding the installation, operation or maintenance of this equipment should be directed to Delta Cooling Towers, Inc., Rockaway, New Jersey, (Telephone: 973/586-2201).

Step-by-step instructions contained in this brochure are based on normal installation conditions only. Abnormal or unusual combinations of field conditions should be brought to the attention of Delta Cooling Towers or its representative prior to installation of the equipment. The information contained herein is subject to change without notice in the interest of product improvement.

---

# Delta Cooling Towers, Inc.

---

## Principle of Cooling Towers

All Cooling Towers operate on the principle of removing heat from water by evaporating a small portion of the water that is recirculated through the unit.

The heat that is removed is called the latent heat of vaporization.

Each one pound of water that is evaporated removes approximately 1,000 BTU's in the form of latent heat.

## Cooling Tower Terms and Definitions

**BTU** - A BTU is the heat energy required to raise the temperature of one pound of water one degree Fahrenheit in the range from 32° F. to 212° F.

**Cooling Range** - The difference in temperature between the hot water entering the tower and the cold water leaving the tower is the cooling range.

**Approach** - The difference between the temperature of the cold water leaving the tower and the wet-bulb temperature of the air is known as the approach. The approach fixes the operating temperature of the tower and is a most important parameter in determining both tower size and cost.

**Drift** - The water entrained in the air flow and discharged to the atmosphere. Drift loss does not include water lost by evaporation. Proper tower design and operation can minimize drift loss.

**Heat Load** - The amount of heat to be removed from the circulating water through the tower. Heat load is equal to water circulation rate (gpm) times the cooling range times 500 and is expressed in BTU/hr. Heat load is also an important parameter in determining tower size and cost.

**Ton** - An evaporative cooling ton is 15,000 BTU's per hour.

**Wet-Bulb Temperature** - The lowest temperature that water theoretically can reach by evaporation. Wet-Bulb Temperature is an extremely important parameter in tower selection and design and should be measured by a psychrometer.

**Pumping Head** - The pressure required to pump the water from the tower basin, through the entire system and return to the top of the tower.

**Make-Up** - The amount of water required to replace normal losses caused by bleed-off, drift, and evaporation.

**Bleed Off (Blowdown)** - The circulating water in the tower which is discharged to waste to help keep the dissolved solids concentrating in the water below a maximum allowable limit. As a result of evaporation, dissolved solids concentration will continually increase unless reduced by bleed off.

# Installation of Your Pioneer® Cooling Tower

## Safety Procedures

### CAUTION:

Observe safety procedures during installation and whenever construction is under way.

- ❑ Always disconnect & lock out main power supply before working on motors and other electrical equipment.
- ❑ Stand clear of rotating equipment during start-up.
- ❑ Before start-up replace all guards removed during installation, that protect pinch areas of V-belts, sheaves and other rotating equipment.
- ❑ Avoid contact with open flame or heat source that could cause combustion.

Observe recommended safety precautions whenever construction involving welding, a cutting torch, a blowtorch or any other such equipment is under way within the immediate area.

## How to Prevent Reverse Siphoning:

Reverse siphoning is a back flow of non-potable, recirculating water into a potable water system which can occur through the make-up float valve assembly located in the water reservoir of a cooling tower.

Should the valve malfunction, blockage of the overflow or outlet lines would cause a high water level in the reservoir, causing the make-up water pressure to drop below atmospheric pressure creating a vacuum at the make-up inlet.

To prevent reverse siphoning, install a check valve in the water make-up supply line to the cooling tower.

*NOTE: Do not cap the overflow connection.*

## Location of the Pioneer® Cooling Tower

Proper location of the cooling tower is essential to its satisfactory operation. The following are recommendations for selecting a cooling tower location. Consult the factory or our representatives for additional assistance in selecting equipment and equipment locations.

- ❑ Select an open site having an unobstructed air supply and free air motion.
- ❑ If the site is adjacent to a wall or other

structure that blocks prevailing winds, install the cooling tower so the top discharge is slightly higher than the structure. Locate blower at the farthest point from the structure, facing the direction of the prevailing winds.

- ❑ Gravity drain to an indoor storage Sump requires proper head differential and pipe design considerations. Allowance must be given based on flow, pipe size, piping layout and distance cooling tower is located from the indoor storage sump. (See chart page 3)
- ❑ Should it be necessary to locate the cooling tower near walls, within enclosures, or indoors, choose a location that will not restrict airflow. Do not install the cooling tower in a well or below the level of an obstruction that might impede air discharge, cause short circuit of air flow, or result in recirculation of the discharge air back into the blowers.
- ❑ Do not locate the cooling tower near heat-generating equipment, exhaust vents or pipes which could interfere with the temperature of inlet air and raise the ambient wet-bulb temperature to the cooling tower.
- ❑ Do not install a canopy or roof of any kind over the cooling tower that would deflect discharge air back down around the cooling tower and cause recirculation of the discharge air back into the blowers.

## Hoisting

### Cooling Tower

For roof mounted installations, it is recommended that a hoist using two or more safety slings and spreader bars, as shown in the illustration, be used to lift the cooling tower onto the building.

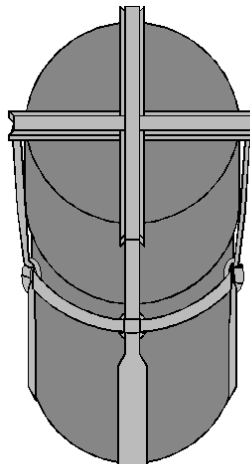

Recommended Hoist for Cooling Tower

Secure the safety slings completely around and under the cooling tower. Provide padding to protect the edges of the polyethylene shell at points of sling contact. The slings should be secured in a girdle fashion for a double secure point of lift. Slings should be brought up snug around the tower before lifting onto the building.

*NOTE: Do not use guy wire U-bolts for hoisting.*

## Blower Assembly

The blower assembly should be hoisted separately onto the building, prior to the removal of the shipping skid, in the same manner as the cooling tower.

*Note: Do not use blower support frame for hoisting.*

Any questions regarding hoisting for roof mounted installations should be directed to Delta.

## Cooling Tower Installation

Delta cooling towers have been designed to provide maximum performance, long life and trouble-free service. To assure optimum performance, the following recommendations should be followed as closely as possible.

## Positioning the Tower

The cooling tower should be installed on a continuous firm, smooth and level concrete, steel or wood foundation.

*Note: The tower must be anchored to the foundation with ¼" guy wires using the four U-bolts provided at the top of the cooling tower shell. Hand tightening of guy wires is sufficient. Do not over-tension.*

Spacing for piping and service access should be considered when positioning the cooling tower. Also to insure an adequate positive suction head, the pump should be located below the bottom of the cooling tower sump.

## Indoor installation

Typically, cooling towers are placed outside, either on the roof or adjacent to a building. If the situation dictates indoor installation, make sure there is ample fresh air available around the blower inlets of the tower. Restricted amounts of fresh air will lead to poor tower performance. It is also necessary to attach a duct to the tower discharge to convey the hot, humid air to the outside. All ducting should be independently supported and be kept as short and straight as possible. The duct size must not be smaller than the inlet and

discharge openings. Blowers may require adjustment to accommodate ducting for indoor installation. Consult the factory for the recommended motor and drive selection when duct exterior static pressure (ESP) is 1/8" W.C. or greater. It is recommended that the inlet and discharge ducting be screened to prevent foreign objects from entering. Should prevailing winds blow into a horizontal discharge, it is recommended that a suitable windbreak be installed several feet away.

**Cold Weather Protection**

The cooling tower may require protection against freezing at light heat loads when the wet-bulb temperature is under 32°F, or during shutdown when the temperature drops below 32°F.

The following methods are recommended for use with Delta cooling towers for protection during cold weather conditions. Recommended equipment is optional and may be ordered from the factory. Consult the factory for further information on which equipment to choose for your specific application.

**Separate Indoor Sump**

This method is a virtually foolproof anti-freeze protection system with the added advantage of minimum maintenance. The indoor sump tank should be large enough to fill the entire recirculation system without danger of pump cavitation. As a general rule, the tank should be sized to hold three times the rate of circulation in gallons per minute (gpm).

The tank should be provided with properly sized overflow, makeup, drain and suction connections. When a separate sump tank is ordered with a cooling tower, the water makeup valve assembly and the overflow and drain connections are installed in the indoor sump only. A bottom outlet can be provided for gravity drain to indoor sump tank installations.

When a sump tank is used, the cooling tower should be located high enough above it to allow free cold water gravity drain, as the chart below outlines.

**Gravity Drain Outlet Size Selection Chart**

Outlet Size (inches)	GPM				
	2	3	4	6	
0.5	20	50	75	165	
1	25	65	95	215	
2	35	90	135	305	
3	40	110	165	370	
4	47	125	190	430	
5	53	140	215	475	
6	57	155	235	525	
7	62	165	250	565	
8	66	180	270	600	
9	70	190	285	645	
10	74	200	300	675	
12	81	220	325	715	
15	90	245	365	825	

*Notes: The above gpm flow rates, for the outlet sizes shown, are calculated for cold water gravity drain through piping designed for direct and short horizontal runs before dropping vertically to the indoor sump tank, See illustration on page 6.*

Long distance horizontal pipe runs, as well as excessive turns, may cause pressure losses that prevent free gravity flow through the outlet sizes shown. Consult Delta for further information.

**Electric Immersion Heater**

Cooling towers ordered with anti-freeze systems are shipped with a protective seat secured under the immersion heater element that is to remain in place during operation to protect the polyethylene shell from direct contact with the heater element.

*Note: This protective seat is not a shipping brace and must not be removed.*

**Suggested Cooling Tower Installation for Dry Basin Operation with Indoor Storage Sump Tank**

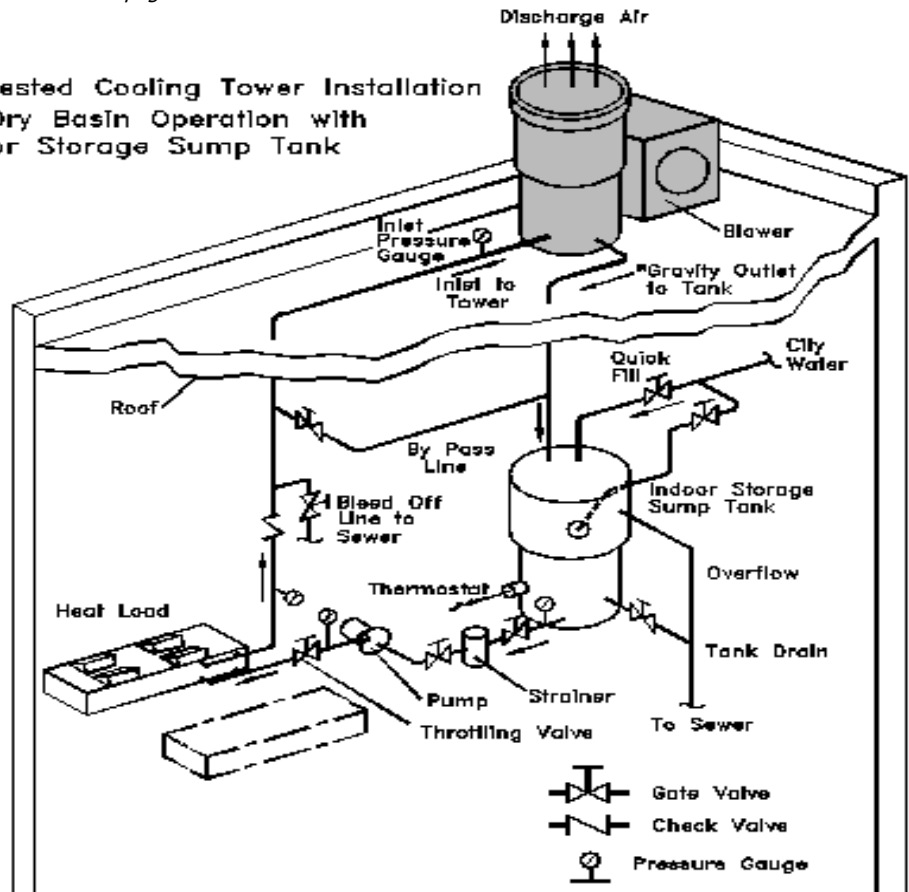

\*An outlet in the bottom of the cooling tower can be provided in place of the standard side outlet for gravity return installations.

### Thermostatic On-Off Control

A thermostatically controlled blower for on-off operation should be considered as an energy-saving feature during winter operation. The thermostatic control can be field set to insure automatic blower shut-down when cold water drops below design temperature, as well as blower start-up when cold water rises to design temperature. A thermostatic control provides excellent cooling tower anti-freeze protection while reducing operating costs through out cold weather operation.

### PVC Distribution system

To prevent damage to the PVC distribution system during cold weather shut-down, install an automatic or manual drain line from the hot water inlet piping as close to the cooling tower inlet as possible. Locate this drain line to allow the water to drain either to waste or to an indoor storage tank. This precaution will prevent water from being trapped and possibly freezing inside the distribution system.

### Piping

When the cooling tower is located outdoors, adequate measures including the use of heat tracing tape and insulation should be considered to protect outdoor water lines from freezing.

### Piping and Tower Connections

□ Piping should be adequately sized according to accepted standard practices. Refer to cooling tower drawings for size and types of cooling tower connections furnished as standard.

□ On multiple tower installations, pipe sizing should balance pressure drops to provide equal inlet pressures. Equalizing fittings can be provided in cooling tower sumps and are available as an option from the factory. Each unit should be valved separately to allow for flow balance or isolation from service.

□ All supply and return piping must be independently supported. See page 5 for instructions for the preparation and cementing of internal and external piping.

□ An inlet pressure gauge should be installed immediately before the cooling tower inlet connection. See Operating Design Condition Checklist page 6, and illustration page 3.

□ The makeup connection is provided with a float valve and ball assembly for proper water level control.

□ The overflow connection includes an elbow with extension pipe that drops below the water level in the tower sump.

*Note: Never block overflow connection. Water should be allowed to flow freely without obstruction. See how to prevent reverse siphoning page 2.*

□ The outlet connections for pump suction applications are provided with a vortex breaker.

*Note: For gravity flow applications, a vortex breaker is not required or provided. A vent pipe or bleed valve should be installed at the highest elbow of the piping system, to prevent air locks and insure free flow of water. Air locks can cause gravity flow restriction resulting in excessive water accumulation and eventual overflow of the cooling tower.*

□ The outlet, makeup and overflow connections are notched at the outer ridge and should be held in position with the notch at 12 o'clock. This is to insure proper position of the vortex breaker, float valve, assembly and overflow extension which are internal and not visible from the exterior of the cooling tower.

□ The inlet fitting of models DT-10 through DT-40 is notched in the same manner as described above to insure proper spray nozzle position.

□ PVC bulkhead connections must be held steady and in their factory-installed positions when the connecting piping is being installed.

□ When threading pipe to the bulkhead fittings, do not allow fittings to turn. Turning can loosen the locknut or squeeze the gasket out of position and may cause leaks. PVC bulkhead fittings should be tightened with a chain wrench so that the gaskets sit properly between the cooling tower shell and the fitting. Do not over tighten. A bulkhead fitting that is too tight or too loose can cause the gasket to crimp or squeeze away from the locknut, causing leaks around these connections.

### Duct To Blower Housing Installation

□ To install the cooling tower air duct to the blower housing, place the lip of the duct over the lip of the blower housing as shown. With seven screws supplied, fasten duct to housing using two screws on each side and three on the bottom.

On models DT-10 through DT-25, install the duct sides outside the blower housing.

On all other models, install the duct sides inside the blower housing.

Install bottom of the duct to outside of the blower housing on all models.

□ Seal off air leaks around the duct with duct tape.

*Note: the blower support frame must be bolted to the foundation. The assembly is furnished with pre-drilled bolt holes. Shimming may be required for perfect fit.*

□ Damage to painted surface of blower housing during installation must be repaired immediately to prevent corrosion.

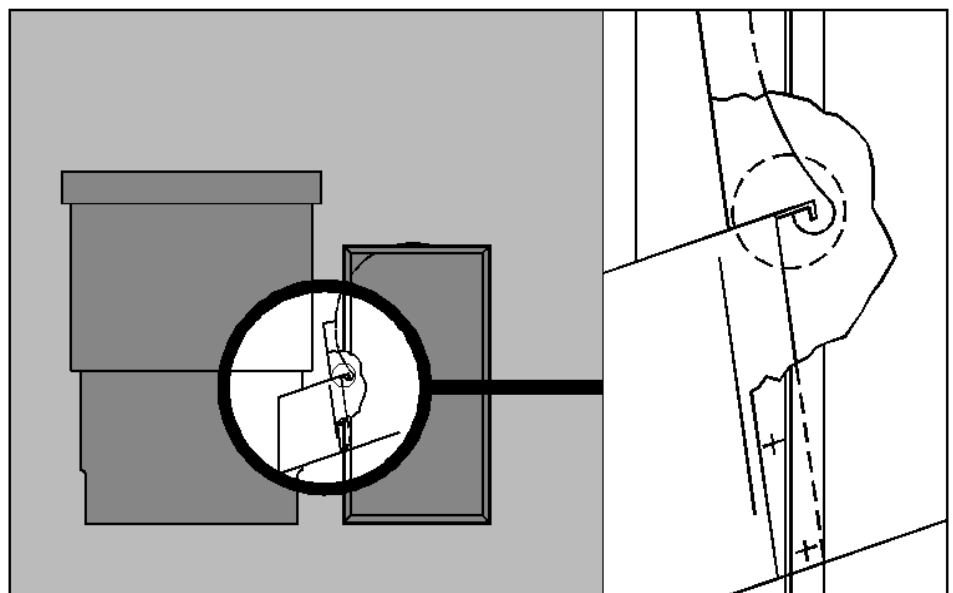

Duct to Blower Housing Installation

## PVC Solvent Cementing Instructions

The following procedure is recommended for the preparation and cementing of internal and external piping for Delta cooling towers:

- ❑ Cut ends of pipe square using a hand saw and miter box. Tube cutters with wheels designed for use with PVC are acceptable, providing they do not leave a raised bead on the outside diameter of the pipe.
- ❑ Use a chamfering tool or file to put a 10° to 15° chamfer on the end of the pipe. Lightly sand the area to be cemented to remove gloss. Using a clean rag, wipe pipe surface and fitting socket to remove dirt, moisture and grease, Acetone or similar solvent is recommended for cleaning.
- ❑ Check "dry fit" of pipe and fitting by inserting the pipe at least 1/3 of the way into the fitting. Position pipe and fitting to assure alignment. Pipe and fitting should be at same temperature condition.

Using a clean, natural bristle brush about 1/2 and size of the pipe diameter, apply P-70 primer to the fitting socket, Apply primer with a scrubbing motion until the surface is penetrated. Primer should never be applied with a rag. Repeated applications may be necessary to achieve the desired dissolving action. In the same manner, apply primer to the pipe surface equal to the depth of the fitting socket, making sure the surface is well penetrated. Reapply primer to the fitting socket to make sure it is still wet.

- ❑ While both surfaces are still wet with primer, use a clean brush to apply a liberal coat of solvent cement to the male end of the pipe. The amount should be more than sufficient to fill any gap.

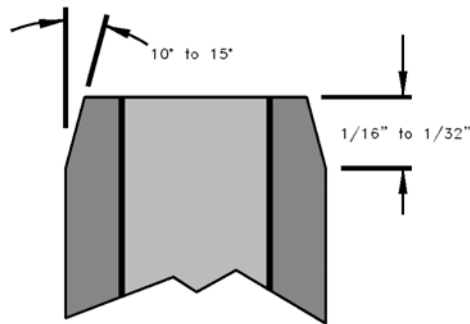

- ❑ While both surfaces are still wet with solvent cement, insert the pipe into the socket with a quarter-turn twisting motion. The pipe must be inserted the full length of the socket.

The application of solvent cement to pipe and fitting, and the insertion of the pipe into the fitting, should be completed in less than one minute. If necessary, two persons should apply solvent cement to the pipe and fitting simultaneously.

- ❑ Hold the joint together for approximately 30 seconds until both surfaces are firmly gripped. After assembly, a properly made joint will usually show a bead of cement around its entire perimeter. This should be brushed off.

It is recommended that the joint be allowed to cure for 24 ours before pressure testing.

## Operation of Your Pioneer® Cooling Tower.

### V-belt Alignment and Tensioning

Proper belt tension is the most important factor in the successful operation of a V-belt drive. The belt tension should be checked frequently during the first 24 hours of operation and then periodically on a maintenance schedule. Loose belts cause slippage which reduces air flow and can adversely affect belt life and cooling tower performance.

The following belt tensioning procedure is recommended:

- ❑ Check that the driver and driven sheaves are in alignment by placing a straight edge across the sheaves at four contact points as shown. If realignment is required, loosen the motor sheave bushing screws and align the sheaves.
- ❑ To tension the belts, adjust the motor base so that the belt will deflect about 1/2" when moderate pressure is applied to the

belt midway between the sheaves as shown in the illustration.

*Note: Excessive belt tension can shorten belt and bearing life. Loose belts or misaligned sheaves can cause unseating and breakage of belts. Replacement of multiple belt systems should be made in matched sets.*

### Initial Start-Up

- ❑ Clean accumulated debris from inside shell bottom.
- ❑ Check that blower fan motor is properly wired for counter-clockwise (ccw) rotation of the blower wheel as viewed from the sheave side of the blower assembly. Reverse leads will cause incorrect rotation and inhibit required airflow.
- ❑ Fan bearings should be re-lubricated if tower has been in the field three months or longer prior to start-up.
- ❑ Check sheave alignment and belt tension. See illustration.
- ❑ Fill cold water sump to overflow level.

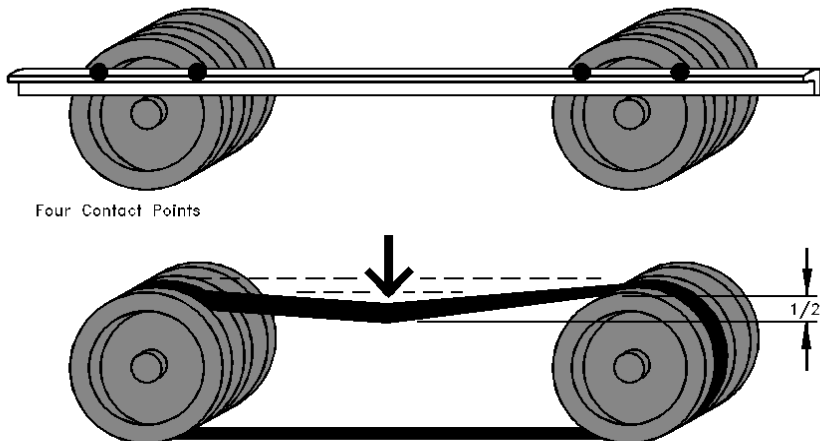

Four Contact Points

Proper Belt Tension

The standard make-up valve assembly is shipped as shown with the plastic float ball against the tower side to prevent damage. To set the ball for proper operation, loosen the thumb screw on the fulcrum arm and rotate until a 10" operating level is obtained (measured from the tower bottom vertically upward to the midpoint of the float ball). It is recommended that a shut-off valve be installed in the make-up line. See how to prevent reverse siphoning page 2.

### Make-up Valve Assembly

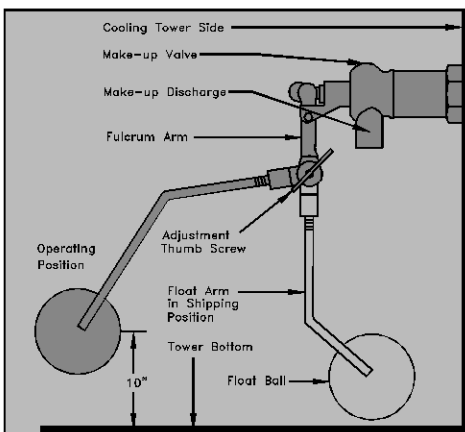

- ❑ Water recirculation pump(s) should be primed and all piping below the tower sump filled with water. Check pump for proper shaft rotation.
- ❑ Start water recirculation pump(s) and adjust flow to produce proper inlet spray pressure. An inlet pressure gauge should be installed immediately before the cooling tower inlet connection.

- ❑ Check spray pattern from nozzle(s) to be sure there is no clogging, Remove drift eliminators for nozzle inspection, then return to proper position.
- ❑ Start fan motor and check amperage and voltage against motor nameplate data.
- ❑ After 24 hours of operation, check belt tension and adjust if necessary. See page 5.

### Operating Design Condition Checklist

For proper operation and maximum efficiency of the cooling tower, the following operating design conditions are essential:

- ❑ The flow rate of the cooling tower must be as close to the design gpm as possible. The distribution system, including spray nozzles, are provided for the design flow condition. Under-pumping or over-pumping will cause the cooling tower to perform inefficiently.
- ❑ Design pressure at the inlet connection must be maintained for proper water distribution. If the pressure is less or greater than the design, proper water dispersion over the internal wet decking will be impaired. If inlet pressure is low, water spray will not cover the entire wet decking surface. This causes channeling of air and does not make maximum use of the heat transfer media. High inlet pressures will cause the water to over-spray the wet decking media, hit the internal side walls of the tower shell and drop in a vertical flow along the shell walls without the opportunity for maximum water / air contact through

the heat transfer media. Excessive high spray pressure may also cause wet decking fatigue and damage. The nozzles furnished with standard cooling towers are sized for 3 gpm/ton, requiring 10 psi inlet pressure for models DT-50 through DT-100, and 7 psi inlet pressure for models DT- 10 through DT- 40. This standard may vary when the design flow is less or greater than 3 gpm/ ton. Alternate orifice nozzles will be provided in order to maintain the proper inlet pressure requirement. Correct flow rates and inlet pressures should be determined prior to completion of system installation.

- ❑ Blower motors must be properly wired for counter-clockwise (ccw) rotation of the blower wheel as viewed from the sheave side of the blower assembly. Reversed leads will cause incorrect rotation and inhibit required air distribution.

*Note: The blower must always operate with water circulating through the cooling tower to prevent motor overload.*

- ❑ The maximum operating inlet water temperature should not exceed 140° F.

Model	Nozzle Size	Inlet Pressure
ΔT-50 through ΔT-100	3 gpm/ton	10 psi
ΔT-10 through ΔT-40	3 gpm/ton	7 psi

## Maintenance of Your Pioneer® Cooling Tower.

### Water Treatment

The Delta cooling tower shell and internal components are fabricated of corrosion-resistant plastics and are resistant to water treatment chemicals including common fungicides and bactericides.

Follow appropriate water treatment practices as required and take frequent sample tests to avoid possible water contamination. We also recommend water treatment maintenance as a measure of protection for the environment in the vicinity of any cooling tower or evaporative condenser equipment.

To determine the appropriate water treatment practices for your particular application, it is suggested that you contact a water treatment firm for their recommendation. A list of water treatment firms is available for your reference.

It is not necessarily complete nor do we recommend a specific firm. The list will be mailed to you on request. Bleed off is also important to water quality. Evaporation of the recirculated water does not remove the dissolved solids that are present in the water. Without bleed off, the continual buildup of these solids will impair the proper functioning of the piping and other equipment in the system.

A bleed line can be connected in any part of the system with routing to the sewer. Normally, it is most desirable to make this connection in the hot water line at the cooling tower. A petcock type valve, installed in the bleed line for proper control is recommended. The required amount of bleed-off water must be substituted with properly controlled amounts of make-up water.

## **Disassembly and Cleaning**

### **For Pioneer® Models DT-10 through DT-40**

❑ Remove the drift eliminator from the cooling tower. It is flexible enough to push the outer perimeter toward the center and lift over the top lip of the cooling tower shell. Begin at one point and work carefully around the entire circumference of the drift eliminator.

❑ Models DT-30 and DT-40 are designed without a top lip so the drift eliminator can be easily lifted up and away from the shell.

❑ Remove the water distribution spray system from inside the cooling tower. The spray system is installed across the top of the tower directly under the drift eliminator. Disconnect locknuts at each end of system and remove piping by elongating top of tower shell slightly.

❑ Remove the wet decking from the cooling tower shell using the plastic hand straps attached for lifting. The wet decking has a smaller diameter than the drift eliminator and will lift easily out of the shell once the distribution spray system is removed.

❑ When the internal components are removed the empty shell can be cleaned and inspected, It is recommended that the water distribution laterals and nozzles be cleaned and flushed before reassembly.

❑ To reassemble components, reverse the above procedure.  
Before installing the drift eliminator, pump water through the distribution system to be sure there is a good spray pattern and proper water distribution over the wet decking surface.

### **For Pioneer® Models T-50 through T-100**

Same procedure as above except:

❑ These models are designed so the drift eliminator can be easily lifted up and away from the cooling tower shell. The spray tree sections of the water distribution system are threaded to a coupling and unscrew easily. Hold and turn the entire riser below the lateral and nozzles, then carefully remove the whole assembly.

❑ The wet decking can now be easily removed using the plastic hand straps attached for lifting.

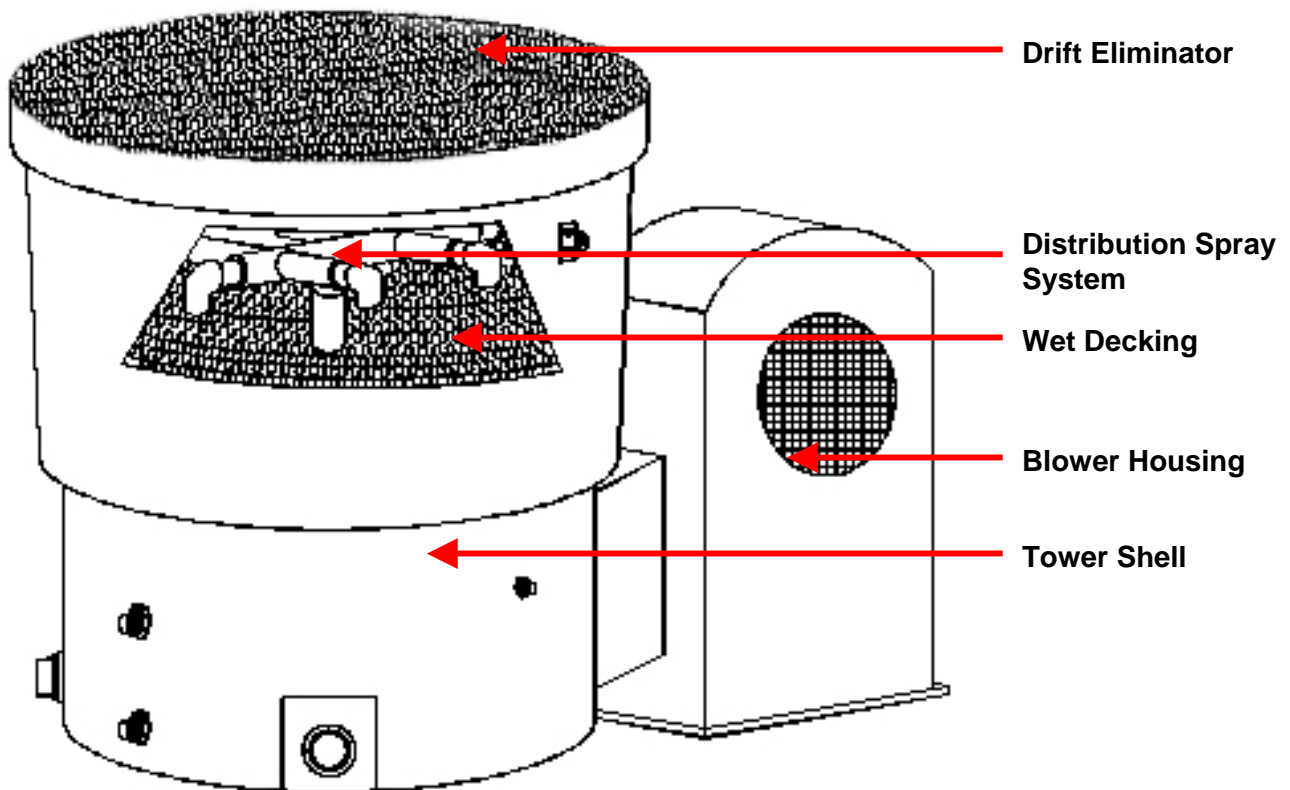

**Preventative Maintenance Checklist**

Procedure	Monthly	Every 3 Months	Every 6 Months
Inspect general condition of cooling tower. (it is never necessary to scrape or paint a Delta Cooling Tower.)	❖		
Check water level in cold water basin. Adjust if necessary.	❖		
Check float ball and make-up valve for proper operation.	❖		
Check line voltage, motor amperage and fan wheel rpm.	❖		
Check belt tension and general condition of V-belts.	❖		
Clean outside of blower motor to help assure proper cooling.		❖	
Lubricate blower bearings and fan motor using a low pressure grease gun.		❖	
Check blower wheel for dirt buildup which can cause unbalance and vibration		❖	
Clean and flush cold water basin.			❖
Lubricate motor base and adjusting screw.			❖

**Pioneer®  
Recommended  
Replacement Parts**

To avoid costly cooling tower downtime, the following replacement parts should be carried in inventory at the installation site:

- V-belts
- Blower bearings
- Make-up float, or complete make-up valve assembly
- Blower shaft
- Blower motor
- Or, a complete blower assembly including bearings, shaft, sheaves, V-belts and motor.

When ordering, include model number and serial number of the cooling tower as it appears on the tower nameplate.

Under normal conditions, shipment of factory replacement parts is made within one day after the order is received. Spare pumps and pump parts as well as control panel components, such as fuses and heaters for magnetic starters, are also available.



## CONDITIONS OF SALE AND WARRANTY

### Terms and Conditions

1. **Sale Not a Consumer Transaction:** Buyer agrees that the purchase of Delta's Products (hereinafter "Product") is not for consumer, household or family purposes.
2. **Agreement of Sale: Acceptance:** Any acceptance contained herein is expressly made conditional on Buyer's assent to any terms contained herein that are additional to or different from those proposed by Buyer in its purchase order and hence any terms and provisions of Buyer's purchase order which are inconsistent with the terms and conditions hereof shall not be binding on the Seller. Unless Buyer shall notify Seller in writing to the contrary as soon as practicable after receipt hereof, acceptance of the terms and conditions hereof by Buyer shall be deemed made and, in the absence of such notification the sale and shipment by the Seller of the goods covered hereby shall be conclusively deemed to be subject to the terms and conditions hereof.
3. **Entire Contract:** This contract constitutes the final and entire agreement between Seller and Buyer and any prior or contemporaneous understandings or agreements, oral or written are merged herein. The sales and technical representatives of the Seller are not authorized to make warranties about the product. Sellers representatives' oral statements do not constitute warranties, shall not be relied upon by the Buyer, and are not part of the contract for sale. Any product literature and operating instructions, and statements contained therein, do not constitute warranties, shall not be relied upon by the Buyer and are not part of the contract for sale. The entire contract is embodied in this writing and no other warranties are given beyond those set forth in this contract. This writing constitutes the final written expression of the parties agreement, and it is a complete an exclusive statement of the terms of the agreement.
4. **Prices:** Except where expressly agreed, all prices are subject to change without notice. If there is a delay in approval of drawings related to this contract beyond 30 days, an escalation in selling price may occur due to a rise in labor and/or material prices.
5. **Taxes:** The price of goods does not include sales, use, excise, ad valorem, property or other taxes now or hereinafter imposed, directly or indirectly by any governmental authority or agency with respect to the manufacture, production, sale, delivery, consumption or use of goods covered by this contract. Buyer shall pay such taxes directly or reimburse Seller for any such taxes which it may be required to pay.
6. **Payment:** The specific terms of payment are as specified in writing by Seller. If the Buyer shall fail to make any payments in accordance with the terms and provisions hereof, the Seller, in addition to its other rights and remedies, but not in limitation thereof, may, at its option, defer shipments or deliveries hereunder, or under any other contract with the Buyer, except upon receipt of satisfactory security or of cash before shipment.
7. **Shipment; Risk of Loss Title:** The goods shall be shipped FOB Seller's shipping points. Risk of loss shall pass to Buyer upon delivery to the carrier. Title shall pass to Buyer on delivery to the carrier.
8. **Delivery; Delays in Deliveries:** The date of delivery provided herein is an approximation based on Seller's best judgement. Seller shall be excused for delay in delivery, may suspend performance and shall under no circumstances be responsible for failure to fill any orders when due to acts of God or of the public enemy; fires; floods; riots; strikes; freight embargos or transportation delays; shortage of labor; inability to secure fuel; material supplies, or power at current prices or on account of shortages thereof; any existing or future laws or acts of the Federal or of any State Government (including specifically, but not exclusively, any orders, rules or regulations issued by any official or agency of any such government).

9. **LIMITED WARRANTY:** Seller warrants that the cylindrical, seamless molded polyethylene shell of the Product shall be free from defects in materials and workmanship and will not peel, chip, rust or need painting for a period of fifteen (15) years from the date of shipment. Since the Product once in operation is under the sole control of the User, this warranty is further subject to and shall be applicable only if all of the following conditions are met:
  - a. The Product has been properly erected in accordance with the Seller's instructions and in accordance with good installation practices;
  - b. Seller's instructions and recommendations as to operation and maintenance have been followed, including those contained in the manual furnished with the Product;
  - c. The Product has been used under normal operating conditions;
  - d. The Product has not been affected by misuse, neglect, accident or abrasion;
  - e. The User has not attempted or performed corrective work on the Product without Seller's prior written consent; and
  - f. The Seller shall have received notice of any defect no later than 10 days after User first has knowledge of same.

Except where expressly noted otherwise, Seller warrants all Product components, other than moving parts, against defects in workmanship and material for a period of one (1) year from the date of shipment, provided the equipment has been properly maintained and operated under normal conditions. Motors and blowers carry a normal manufacturer's one (1) year warranty against defects in workmanship and materials beginning from the date of shipment and subject to the same conditions of proper use and operation as other components of the Product. Bearings, pulleys, belts or other moving parts and components are sold without any warranty.

10. **DISCLAIMER OF ALL OTHER WARRANTIES AND GUARANTEES:** The aforesaid warranty is the sole and only warranty or guarantee relating to the product provided under this Agreement, and is in substitution for, and in lieu of, any and all other warranties, written or oral, expressed, implied or statutory including any warranty of merchantability or of fitness for a particular purpose.

11. **CORRECTION OF DEFECTS AS SOLE REMEDY:** If the Buyer/User gives the Seller written notice of defects in the product within any period of warranty described herein and the Seller's inspection confirms the existence of such defect, the Seller, at its option, shall correct the defect or defects either by repair, providing repair tools and instructions, or replacement, FOB Seller's shipping point, or refund the purchase price of the product. The remedies provided Buyer/User herein for breach of Seller's warranty shall be exclusive. No expense, liability or responsibility will be assumed by the Seller for repairs made by other than Seller's agent without written authority from the Seller. Remedial action, in the manner and for the period of time provided above, shall constitute fulfillment of all liabilities of Seller to the Buyer / User, and Buyer/User's sole remedy hereunder, whether based on contract, tort or otherwise. The sole purpose of stipulated exclusive remedy shall be to provide the User with free repair and replacement of defective parts in the manner provided herein. This exclusive remedy shall not be deemed to have failed of its essential purpose so long as the Seller is willing and able to repair or replace defective parts in the prescribed manner. An action for breach of this limited warranty or any other action otherwise arising out of this contract must be commenced within one (1) year from the date the right, claim, demand or cause of action shall first occur, or be barred forever.

12. **STATEMENT OF BUYER/USER'S RESPONSIBILITIES:** It is the sole responsibility of the Buyer/User, and not in any manner the responsibility of the Seller, to test, control and properly dispose of all discharges, both gaseous and liquid, from the product to assure:
  - a. Compliance with all federal, state and municipal (or any political subdivision thereof) statutes, laws, codes, ordinances, rules and regulations concerning the environment, including but not limited to: The Clean Air Act, 42 U.S.C. S7401 *et seq.*; The Clean Water Act, 33 U.S.C. S1251 *et seq.*; The Comprehensive Environmental Response, Compensation and Liability Act, 42 U.S.C. S9601 *et seq.*; The Toxic Substance Control Act, 15 U.S.C. S2601 *et seq.*; The Resource Conservation and Recovery Act, 42 U.S.C. S6901 *et seq.*; The Safe Drinking Water Act, 21 U.S.C. S349 *et seq.*; The National Environmental Policy Act, 42 U.S.C. S4321 *et seq.*; Occupational Safety and Health Act, 29 U.S.C. S651 *et seq.*; together with any amendments thereto and regulations promulgated thereunder;
  - b. Adequate protection for the health and safety of people, property, wildlife and environment; and
  - c. Adequate protection for all persons, including employees, coming in contact with the Product and its discharges for all purposes including, without limitation, installation, maintenance, use and repair of the Product.It is also the sole responsibility of the Buyer/User to:
  - d. Maintain the Product in accordance with the "Installation, Operating and Maintenance Instructions";
  - e. Comply with the maintenance checklist contained in the "Installation, Operating and Maintenance Instructions"; and
  - f. Periodically monitor and test the Product to verify proper functioning, and to insure the Product performs properly.It is further the sole responsibility of the Buyer/User to comply with all laws, codes, and regulations relating to the Product and its use and Seller makes no warranty or representation with respect thereto. Buyer/User assumes the responsibility for providing and installing all devices required to protect the health and safety of people, property, wildlife and the environment. Buyer/User acknowledges having read the "Installation, Operating and Maintenance Instructions", including all warnings contained therein, and is aware of the precautions recommended for protection to the health and safety of people, property, wildlife, and the environment, including employees coming in contact with the Product discharges. Buyer/User assumes full responsibility to assure proper use of the Product, including the determination and control of what chemicals, pollutants and toxic substances are introduced into the product, and the determination and control of all discharges from the Product.
13. **DISCLAIMER OF TORT, CONTRACT, STATUTORY AND ALL OTHER LIABILITY:** The Seller hereby disclaims all tort, contract or statutory liability to the Buyer/User, and any other basis of liability to Buyer/User regarding claims for injury or damage to people, property, wildlife, or the environment, including, without limitation, claims of negligence, strict product's liability, breach of warranty (except the limited warranties as provided in paragraph 9 entitled: "Limited Warranty"), breach of contract or violation of statute, law, ordinance, code, rule or

Delta Cooling Towers

regulation. Seller also disclaims any liability to the Buyer/User in contribution or indemnification for the Buyer/User's liability or alleged liability to any third person or entity for injury or damage to people, property, wildlife or the environment. Without limiting the generality of the foregoing, Seller disclaims liability for all claims for compensatory, consequential, incidental or other damages and for damages for personal injury and property damage, loss of use, revenue or profit, injury to good will, inability to fulfill contracts to third parties, other economic loss, response costs and other environmental clean-up costs or other damages arising out of the actual, alleged or threatened discharge, dispersal, release or escape of pollutants, contaminants, hazardous waste, or liquid or gaseous materials discharged from or through the Product and any loss, cost or expense arising out of any governmental or other direction or request to test for, monitor, clean-up, remove, contain, treat, detoxify or neutralize the foregoing.

Seller also disclaims liability for all claims for damages arising from the actual or alleged violation of any federal, state, municipal (or political subdivision thereof) statute, law, ordinance, code, rule or regulation relating to the environment, including but not limited to: The Clean Air Act, 42 U.S.C. S7401 *et seq.*; The Clean Water Act, 33 U.S.C. S1251 *et seq.*; The Comprehensive Environmental Response, Compensation and Liability Act, 42 U.S.C. S9601 *et seq.*; The Toxic Substances Control Act, 15 U.S.C. S2601 *et seq.*; The Resource Conservation and Recovery Act, 42 U.S.C. S6901 *et seq.*; The Safe Drinking Water Act, 21 U.S.C. S349 *et seq.*; The National Environment Policy Act, 42 U.S.C. S4321 *et seq.*; Occupational Safety and Health Act, 29 U.S.C. S651 *et seq.*; together with any amendments thereto and regulations promulgated thereunder.

Seller further disclaims any liability, direct or indirect, resulting from the Buyer/User's failure to fulfill the responsibilities enumerated in the preceding paragraph entitled "Statement of Buyer/User's Responsibility" including without limitation:

- a. Buyer/User's failure to comply with statutes, laws, codes, rules and regulations relating to the Product and the environment; and
- b. Buyer/User's failure to provide and install all devices required for the protection of the safety and health of people, property, wildlife and the environment and all persons, including employees of the User coming in contact with the Product and its discharges; and
- c. Buyer/User's failure to adhere to the "Installation, Operating and Maintenance Instructions" and the product literature, including all warning contained therein;
- d. Buyer/User's failure to test and monitor the functioning of the Product; and
- e. Buyer/User's failure to determine and control the safety and cleanliness of discharged effluents, both gaseous and liquid, from the Product.

#### 14. EXCULPATORY AND INDEMNIFICATION

**AGREEMENT:** Buyer/User hereby agrees that the Seller will not be liable to the Buyer/User for the matters referred in paragraph 13 entitled "Disclaimer of Tort, Contract, Statutory and All Other Liability." This exculpatory agreement applies even if the defect and/or loss, damage or injury to persons, property, wildlife and the environment resulted solely or in part from the Seller's actual or alleged negligence, breach of warranty, violation an statute, law, ordinance, rule or regulation, or actions resulting in strict liability.

The Buyer/User hereby agrees to defend, hold harmless and indemnify the Seller and Seller's agents from and against all claims, suits, actions, and liabilities for injury or damage to people, property, wildlife, or the environment, including, without limitation, claims of negligence, strict products liability, breach of warranty (except the limited warranties provided in paragraph 9 entitled "Limited Warranty"), breach of contract or violation of statute, law, ordinance, code, rule or regulation. The Buyer/User hereby agrees to defend, hold harmless and indemnify the Seller and Seller's agents from and against all claims, suits, and actions including claims for contribution or indemnification for another's liability or alleged liability to any third person or entity for injury or damage to people,

property, wildlife or the environment.

Without limiting the generality of the foregoing, the Buyer/User hereby agrees to defend, hold harmless and indemnify the Seller and Seller's agents from and against all claims, suits, actions, and liabilities for compensatory, consequential, incidental or other damages and for damages for personal injury and property damage, loss of use, revenue or profit, injury to good will, inability to fulfill contracts to third parties, other economics loss, reponse costs and other environmental clean-up cost or other damages arising out of the actual, alleged or threatened discharge, dispersal, release or escape of pollutants, contaminants, hazardous waste, or liquid or gaseous materials discharged from or through the Product and any loss, cost or expense arising out of any governmental or other direction or request to test for, monitor, clean-up, remove, contain, treat, detoxify or neutralize the foregoing.

The Buyer/User hereby agrees to defend, hold harmless and indemnify the Seller and Seller's agents from and against all claims, suits, actions, and liabilities for damages arising from the actual or alleged violation of any federal, state, municipal (or political subdivision thereof) statute, law, ordinance, code, rule or regulation relating to the environment, including but not limited to: The Clean Air Act, 42 U.S.C. S7401 *et seq.*; The Clean Water Act, 33 U.S.C. S1251 *et seq.*; The Comprehensive Environmental Response, Compensation and Liability Act, 42 U.S.C. S9601 *et seq.*; The Toxic Substances Control Act, 15 U.S.C. S2601 *et seq.*; The Resource Conservation and Recovery Act, 42 U.S.C. S6901 *et seq.*; The Safe Drinking Water Act, 21 U.S.C. S349 *et seq.*; The National Environment Policy Act, 42 U.S.C. S4321 *et seq.*; Occupational Safety and Health Act, 29 U.S.C. S651 *et seq.*; together with any amendments thereto and regulations promulgated thereunder.

The Buyer/User hereby agrees to defend, hold harmless and indemnify the Seller and Seller's agents from and against all claims, suits, actions, and liabilities, direct or indirect, resulting from the Buyer/User's failure to fulfill the responsibilities enumerated above in number 12 entitled "Statement of Buyer/User's Responsibilities" as if the Buyer were the User as referred to therein, including without limitation:

- a. Buyer/User's failure to comply with statutes, laws, codes, rules and regulations relating to the Product and the environment; and
- b. Buyer/User's failure to provide and install all devices required for the protection of the safety and health of people, property, wildlife and the environment and all persons, including employees of the User coming in contact with the Product and its discharges; and
- c. Buyer/User's failure to adhere to the "Installation, Operating and Maintenance Instructions" and the product literature, including all warning contained therein;
- d. Buyer/User's failure to test and monitor the functioning of the Product; and
- e. Buyer/User's failure to determine and control the safety and cleanliness of discharged effluents, both gaseous and liquid, from the Product.

The Buyer/User hereby agrees to defend, hold harmless and indemnify the Seller and Seller's agents from and against all claims, suits, actions, and liabilities as enumerated above without limitation even if said claims, suits, actions, and liabilities are based upon actual or alleged negligence, breach of warranty (other than the limited warranty provided in paragraph 9 entitled "Limited Warranty"), violation of any law, statute, ordinance, rule or regulation, or any other basis of liability on the part of Seller or Seller's agents.

15. **Assignment:** No right or interest in this contract shall be assigned by Buyer/User without prior written agreement by the Seller. No delegation of any obligation by the Buyer/User shall be made without prior written agreement by the Seller.
16. **Modifications; waiver:** No Waiver, alteration or modification of any of the provisions hereof shall be binding on the Seller unless made in writing and agreed to by a duly authorized official of the Seller. No waiver by the Seller of any one or more defaults by the Buyer/User in the performance of any provision of this contract shall perate or be construed as a waiver of any future default or defaults whether of a like or of a different character.
17. **Changes & Improvements:** Seller reserves the right to make changes, and improvements in its Products at any time without notice. Where such change and improvements have been made, Seller

shall not be obligated to incorporate such changes and improvements in Products previously sold to any customer, nor shall Seller be obligated to replace previously sold products with products incorporating such changes and improvements.

18. **Return of Goods:** Where Seller has provided prior written authorization, Seller will accept the return for credit or exchange of products which have been made to the specifications set forth in its catalogs and other literature, provided the product has not been altered or damaged. Products returned for credit will be subject to a 20% restocking charge. Return products must be shipped prepaid to Seller at the location noted in written authorization.
19. **Technical Services:** Upon request of Buyer/User, Seller will endeavor to furnish such technical advice as it has available in reference to the use of its products. Any technical advice furnished by Seller with reference to the use of its products is given and accepted at Buyer/User's risk and the Seller assumes no obligation or liability for the advice given or results obtained.
20. **APPLICABLE LAW:** The validity, interpretation and performance of all terms, conditions, warranties, disclaimers, indemnification and exculpatory provisions, and all other provisions described herein, and any purchase or sale made hereunder shall be governed by the law of New Jersey in force at the date this contract is made. Where not modified by the terms herein, the provision of Article 2 of the Uniform Commercial Code as enacted by the State of New Jersey shall apply to this transaction.
21. **SEVERABILITY:** If any provision or clause of this contract or application thereof to any person or circumstances is held invalid or unconscionable such invalidity or unconscionability shall not affect other provisions or applications of the contract which can be given effect without the invalid or unconscionable provision or application, and to this end the provisions of the contract are declared to be severable.
22. **WAIVER:** If the Seller, at its option, agrees to a waiver of any of the terms and conditions recited herein, such waiver shall not for any purpose be construed as a waiver of any succeeding breach of the same or any other terms or conditions of said contract; nor shall such a waiver be viewed as a course of performance.
23. **BUYER/USER'S ACKNOWLEDGMENT:** User/Buyer acknowledges that he has read both sides of this contract and accepts its terms.