

# Delta Cooling Towers, Inc.

---

## *Paragon<sup>®</sup> Induced Draft Cooling Tower*

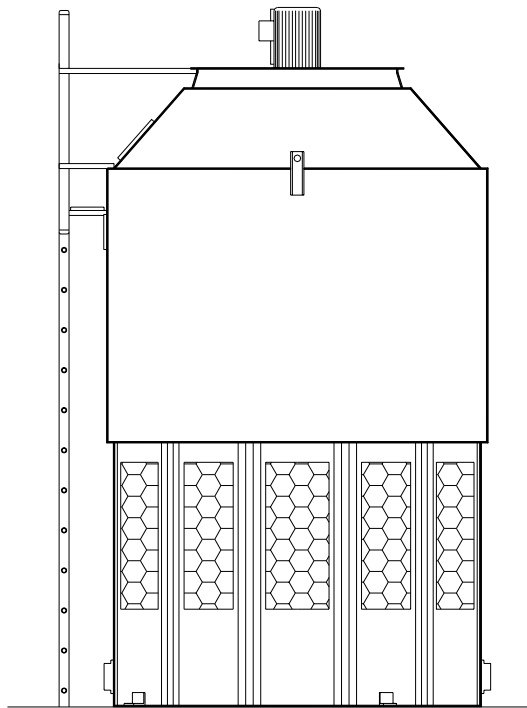

## **Installation, Operation and Maintenance Manual**

---

# Table of Contents

---

<b>Delta Cooling Towers</b>	Principle of Cooling Towers.....	1
	Cooling Tower Terms and Definitions.....	1
	Water Treatment.....	1
<b>General Information</b>	Safety.....	2
	Approximate Weights.....	2
	Dimensions & Other Physical Data.....	2
<b>Handling &amp; Installation</b>	On-Site Inspection.....	2
	Off Loading.....	2
	Handling & Off Loading - Fig. 1.....	2
	Uprighting & Lifting of Cooling Tower.....	3
	Anchoring.....	3
	Water Distribution System/ Tower Internals Pre-Check.....	3
	Water Distribution Sprinkler System – Fig 2.....	3
	Lifting & Installation of the Fan Assembly.....	4
	Electrical Wiring of Fan Motor & Accessories.....	4
	Location, Piping & Connections.....	4
	PVC Solvent Cementing Instructions.....	5
<b>Operation and Maintenance</b>	Safety in Operation of the Fan.....	5
	Water Distribution System.....	5
	Sprinkler Head Maintenance.....	6
	Optional Spray Nozzle Distribution System.....	6
	Direct Drive Fan Assembly.....	6
	Start-up Instructions.....	7
	Water Level in Tower Sump.....	7
	Cold Weather Operation.....	7
	Trouble-Shooting Guide.....	9
	Motor Trouble-Shooting Guide.....	11
<b>Other Information</b>	Cooling Tower Optional Accessories.....	12
	Recommended Replacement Parts.....	12
	Appendices (Reference Documents).....	12
	Preventative Maintenance Checklist.....	13
	Warranty.....	14

---

**Important:** Delta’s cooling towers have been designed to provide trouble-free service over an extended period of time. To obtain the design performance, it is necessary that the cooling tower be installed, operated and maintained as prescribed in these instructions.

Only persons possessing the skill and experience described herein should attempt to install this equipment. **Prior to installation, these instructions should be read carefully** by the person who is to install the cooling tower to be certain that its installation, operation and maintenance are thoroughly understood.

Questions regarding the installation, operation or maintenance of this equipment should be directed to Delta Cooling Towers, Inc., Rockaway, New Jersey, (Telephone: 973/586-2201).

Step-by-step instructions contained in this brochure are based on normal installation conditions only. Abnormal or unusual combinations of field conditions should be brought to the attention of Delta Cooling Towers or its representative prior to installation of the equipment. The information contained herein is subject to change without notice in the interest of product improvement.

---

# Delta Cooling Towers

---

## Principle of Cooling Towers

All Cooling Towers operate on the principle of removing heat from water by evaporating a small portion of the water that is recirculated through the unit.

The heat that is removed is called the latent heat of vaporization.

Each one pound of water that is evaporated removes approximately 1,000 BTU's in the form of latent heat.

## Cooling Tower Terms and Definitions

**BTU** - A BTU is the heat energy required to raise the temperature of one pound of water one degree Fahrenheit in the range from 32° F. to 212° F.

**Cooling Range** - The difference in temperature between the hot water entering the tower and the cold water leaving the tower is the cooling range.

**Approach** - The difference between the temperature of the cold water leaving the tower and the wet-bulb temperature of the air is known as the approach. The approach fixes the operating temperature of the tower and is a most important parameter in determining both tower size and cost.

**Drift** - The water entrained in the air flow and discharged to the atmosphere. Drift loss does not include water lost by evaporation. Proper tower design and operation can minimize drift loss.

**Heat Load** - The amount of heat to be removed from the circulating water within the tower. Heat load is equal to water circulation rate (gpm) times the cooling range times 500 and is expressed in BTU/hr. Heat load is also an important parameter in determining tower size and cost.

**Ton** - An evaporative cooling ton is 15,000 BTU's per hour.

**Wet-Bulb Temperature** - The lowest temperature that water theoretically can reach by evaporation. Wet-Bulb Temperature is an extremely important parameter in tower selection and design and should be measured by a psychrometer.

**Pumping Head** - The pressure required to pump the water from the tower basin, through the entire system and return to the cooling tower.

**Make-Up** - The amount of water required to replace normal losses caused by bleed-off, drift, and evaporation.

**Bleed Off (Blowdown)** - The circulating water in the tower, which is discharged to waste to help keep the dissolved solids concentration of the water below a maximum allowable limit. As a result of evaporation, dissolved solids concentration will continually increase unless reduced by bleed off.

## Water Treatment

- Delta's Cooling Towers are fabricated of non-corrosive engineered plastics which are resistant to water treatment chemicals including common fungicides and bactericides.

- Follow appropriate water treatment practices such as required and take frequent sample tests to avoid possible water contamination. We also recommend water treatment maintenance as a measure of protection for the environment in the vicinity of any cooling tower or other equipment open to atmosphere.
- To determine the appropriate water treatment practices for your particular application, it is suggested that you contact a local water treatment firm for their recommendation.
- Bleed-off is also important to water quality. Evaporation of the recirculated water does not remove the dissolved solids that are present in the water. Without bleed-off, the continual buildup of these solids will impair the proper functioning of the equipment in the system.
- A bleed line can be connected in any part of the system with routing to the sewer. Normally, it is most desirable to make this connection in the hot water line at the cooling tower. A petcock type valve, installed in the bleed line is recommended. Normally, bleed-off of 1% to 2% of the recirculation water flow is satisfactory. The required amount of bleed-off water must be replaced with properly controlled amounts of make-up water.

# General Information

## Safety

When handling, lifting, installing or operating the cooling tower, always employ safe work procedures according to best practices of the trade and according to applicable construction, electrical and safety standards, regulations and codes.

**Follow all safety practices described in these instructions.**

## Approximate Weights

The induced draft cooling towers are manufactured in two basic sections; a polyethylene tower body and a fan assembly section. Both of these sections are factory assembled and packaged separately for field installation.

## Dimensions and Other Physical Data

For cooling tower dimensions, design for foundations, assembly and layout; refer to the following drawings, which are a part of these instructions:

Approximate Weights (lbs.)			Overall Dimensions (inch) W x L x H
Model #	Shipping	Operating	
ΔT-55I	1,180	3,980	84 x 146
ΔT-70I	1,250	4,050	84 x 146
ΔT-85I	1,270	4,070	84 x 146
ΔT-100I	1,510	4,235	84 x 146
ΔT-125I	1,585	4,310	84 x 146
ΔT-150I	1,785	5,570	95 x 179
ΔT-175I	1,925	5,810	95 x 179
ΔT-200I	3,170	8,355	114 x 218
ΔT-250I	3,365	8,500	114 x 218

Model #	Title	Drawing No.
ΔT-55I, ΔT-70I & ΔT-85I	Assembly	DT-D-81-756
	Layout	DT-D-81-755
ΔT-100I & ΔT-125I	Assembly	DT-D-81-754
	Layout	DT-D-81-755
ΔT-150I & ΔT-175I	Assembly	DT-D-83-754
	Layout	DT-D-83-755
ΔT-200I & ΔT-250I	Assembly	DT-D-80-754
	Layout	DT-D-80-755

**NOTE:** Elevation of the center of gravity of the tower body (without fan assembly) is approximately at the top of the ribs.

# Handling and Installation of Your Paragon® Cooling Tower

## On -Site Inspection

Upon arrival at the job site, carefully inspect the shipment for any damage. If shipping damage has occurred, notify the driver or the carrier immediately in writing of all damage. Check that all items listed on the Shipping Bill of Lading have been received.

## Offloading (see Figure 1)

The ΔT-200/250I cooling towers are normally delivered to the site on a "low boy" or "drop deck" trailer. The ΔT-55/70/85/100/125/150/175I cooling towers are normally shipped in a closed van, and can be off-loaded by fork truck. The tower body is shipped strapped down on a skid. The fan assembly with motor is crated separately. Unload the tower body

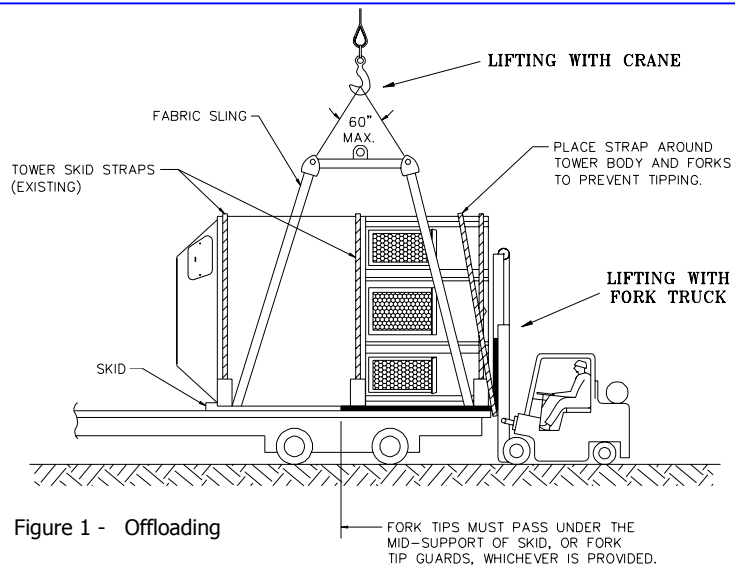

Figure 1 - Offloading

### Lifting with crane:

- Before lifting, inspect skid and banding material and align or repair, if necessary.
- Use fabric slings of sufficient strength for better load distribution and protection of the plastic tower body. Pass slings around the tower body itself. (This procedure should not be used for high or extended lifts unless the skid is secured to the tower body with additional strapping).
- Locate the slings of sufficient strength for better load distribution and protection of the plastic tower body. Pass slings around the tower body itself. (This procedure should not be used for high or extended lifts unless the skid is secured to the tower body with additional strapping).
- Use a spreader bar or crane boom with adequate length straps in order to maintain an angle of 60° or less between slings.

### Offloading with fork truck:

- A fork truck of sufficient capacity may be used for offloading. The forks should pass under the skid along the length of the tower body with the tips of the fork extensions passing under the middle saddle of the skid, or bearing on fork tip supports where they are provided. A strap should be placed around the tower body and forks to secure the load.
- Fork extensions (about 10 ft. long) are necessary for models ΔT-200/250I tower skids.

Store the fan assembly with all shipping padding or bracing in place on the shipping skid in a secure location at the job site until the time of installation. After offloading, store the tower body upright.

**CAUTION:** For extended lifts, use duplicate rigging as an additional safety precaution.

### Uprighting and Lifting of Cooling Tower

- All four (4) sprinkler lateral arms, (see Figure 2), are normally shipped detached and are packaged and secure inside the tower.
- Remove these lateral arms before up-righting and lifting cooling tower.
- Remove shipping skid straps.
- Hooks and cables of sufficient strength should be used for lifting.
- Two (2) aluminum lifting lugs secured to the top of the cylindrical section of the cooling tower are provided for up-righting and lifting

purposes. Install adequate hooks and cable to each of these lifting lugs, lift the cooling tower upright and set it on a smooth, flat and rigid surface. Use guide lines as necessary, to prevent damage to the cooling tower, and as a safety measure to control and avoid sudden shifts or movements of the load.

- **IMPORTANT:** For extended lifts over 25 feet in height, use fabric slings underneath the cooling tower and secure them at the lifting lug location, as an additional safety precaution. Remove air inlet louvers, as necessary, to prevent their damage during handling.
- After re-checking the rigging, lift the tower body and set in place on the previously prepared foundation. Use guide lines, as necessary, to stabilize the load.

- Remove the strut supports attached to the top of the tower and all padding or packaging inside the tower. The shipping supports on top of the fill media, as well as other packaging, may be removed through the inspection port in the side of the cooling tower.
- Replace previously removed louvers.

**CAUTION:** When working inside the cooling tower where the sprinkler system is located, DO NOT step directly on the fill. Use two (2) pieces of 3/8" minimum thickness plywood each at least 12" X 18" to distribute the worker's weight in order to prevent damage to the fill.

### Anchoring

The foundation must be flat, smooth and rigid enough to be capable of independent support of the cooling

tower assembly and water load in the sump at it's maximum level. (Refer to *Dimensions and Other Physical Data.*)

- Four hold-down lugs are provided at the base of the tower with predrilled holes for anchor bolts.
- Final location of anchor bolts should be matched with hold down lugholes at time of installation.
- Use 3/4" diameter anchor bolts (design pull-out load on one bolt is 1,500 lbs. for wind loading).
- Do not shim under the base of the tower to level.
- If shimming of the anchor lug is required, the shim should extend from the bolt to the outside edge of anchor lug. Do not over tighten anchor nuts.
- Check that all the hexagonal bolts on each lug are tight to prevent nuisance leaks. Access can be made by removing one of the air inlet PVC louvers.

### Water Distribution System / Tower Internals Precheck

Before installing the fan ring assembly:

- Check to be sure all bracing, padding and shipping struts have been removed.
- Install the sprinkler lateral arms, which were packaged separately. The center of the hexagonal bolt on the sprinkler head is at the center of the slot located on the sprinkler port. Care should be taken not to over-tighten the bolts, which lock the sprinkler lateral arms in place.

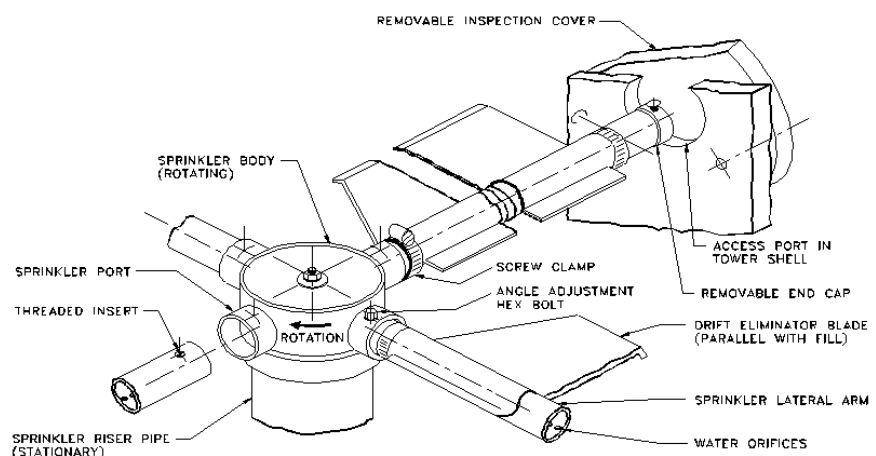

Figure 2 – Water Distribution Sprinkler System

- The drift eliminator blades are preassembled and do not require any adjustment. Simply check to be sure the hose clamps on each end of the lateral arms are tight. With the lateral arms installed, the drift eliminator blades should be parallel with the top of the fill (See Fig. 2).

- Rotate the sprinkler system by hand to be sure it rotates freely.
- Clean-out caps at the end of each lateral arm are in place and are secured with a fastener.

The inspection port in the side of the cooling tower is provided to simplify certain of these check points and to facilitate flushing the sprinkler lateral arms when necessary.

**CAUTION:** As described earlier, when stepping on top of fill, distribute body weight by means of two plywood plates.

**Lifting and Installation of the Fan Assembly**

- Break down fan crate, tip fan assembly, and set the fan ring on the ground before lifting.

- It is recommended that a sealant caulking be placed all around the joint between the fan ring flange and tower shell.

- Lift the fan assembly using the lifting lugs located on the fan ring. (Refer to Figure 3).

- Align the yellow match mark on the fan assembly with the yellow match mark on the tower body.

*Note: If field piping, or equipment location dictates some other orientation, consult Factory. Delta can not be responsible for orientation other than standard, if variations were not known prior to shipment. Costs for field corrections will be the responsibilities of others, and may void equipment warranty if Delta approval is not obtained prior to any field changes.*

- Install eight (8) sets of fan assembly mounting hardware shipped loose with the tower. Use wide washers on the oversize holes in the tower flange. Do not tighten the self-locking nuts until all the bolts are in place. Some out-of-round distortion of the fan mounting flange at the top of the tower may be encountered. To match bolt holes, apply a radial force to the flexible tower body flange. A tapered alignment "drift" pin may be used.

- Recheck the mounting hardware and tighten securely. Recommended torque value is 35 ft.-lbs.

**Electrical Wiring of Fan Motor and Accessories**

- Installation of a vibration cut-out switch is recommended. (Refer to tower accessories available).

- All electrical work should be performed **only** by qualified personnel and in accordance to prevailing electrical codes, practices and safety standards.

- The motor starter should be sized on voltage, nominal horsepower, and **maximum** full load current. This current value can be found on the nameplate. If the starter cannot accept the maximum full load motor current, the next size should be used.

- Motor heaters should be selected on the basics of maximum full load current and service factors based on the motor nameplate.

- Standard "Cooling Tower Service" motors are supplied with a minimum of a 1.15 Service Factor.

- Optional two speed motors are single winding variable torque.

- Run flexible conduit with some slack from the motor conduit box to terminal box outside the tower where rigid conduit can be used.

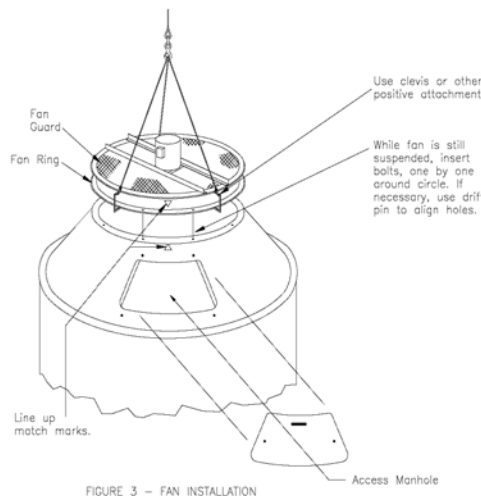

- Conduit holding clip screws can be tapped directly into the tower wall. Use maximum 3/8" screws.

- For the typical wiring schematic of fan motor and tower accessories, see Delta dwg. DT -B-78-001, included with these instructions.

**Location, Piping and Connections**

- Refer to the following drawings included with these instructions for recommended layout and pipe connection information.

Model #	Drawing No.
ΔT-55/85I	DT-D-81-756 DT-D-81-755
ΔT-100/125I	DT-D-81-754 DT-D-81-755
ΔT-150/175I	DT-D-83-754 DT-D-83-755
ΔT-200/250I	DT-D-80-754 DT-D-80-755

- Piping should be adequately sized in accordance with accepted standard practices.

- Gravity drain to indoor storage sump requires proper head differential and piping design considerations. Allowance must be made for flow, pipe size, piping layout and distance of cooling tower from the indoor storage sump.

- On multiple tower installations, valving and/or pipe sizing should balance pressure drops to provide equal inlet pressures. Equalizing lines can be installed between cooling tower sumps and are available as an option from the factory. Each tower should be valved separately to allow for flow balancing or isolation from service.

- Prior to start-up check that the PVC locknuts on all bulkhead fittings are properly tightened to prevent nuisance leaks. A chain wrench can be used to check and tighten the locknuts.

- Check that the SS hexagonal nuts on the inlet and outlet PVC socket flanges are properly tightened to prevent nuisance leaks. While tightening the nuts, do not allow the bolt to rotate. This could damage the rubber seal under the flat washer on the bolt head located inside the cooling tower.

- All supply and return piping must be independently supported.

**PVC Solvent Cementing Instructions**

The following procedure is recommended for the preparation and cementing of internal and external piping for Delta Cooling Towers:

- Cut ends of pipe square using a handsaw and miter box. Tube cutters with wheels designed for use with PVC are acceptable, providing they do not leave a raised bead on the outside diameter of the pipe.
- Use a chamfering tool or file to put a 10° to 15° chamfer on the end of the pipe. Lightly sand the area to be cemented to remove gloss. Using a clean rag, wipe pipe surface and fitting socket to remove dirt, moisture and grease. Acetone or similar solvent is recommended for cleaning.
- Check "dry fit" of pipe and fitting by inserting pipe at least 1/3 of the way into the fitting. Position pipe and fitting to assure alignment. Pipe and fitting should be at same temperature condition.

- Using a clean, natural bristle brush about 1/2 the size of the pipe diameter, apply a primer to the fitting socket. Apply primer with a scrubbing motion until the surface is penetrated. Primer should never be applied with a rag. Repeated applications may be necessary to achieve the desired dissolving action. In the same manner, apply primer to the pipe surface equal to the depth of the fitting socket; making sure the surface is well penetrated. Re-apply primer to the fitting socket to make sure it is still wet.
- While both surfaces are still wet with primer, use a clean brush to apply a liberal coat of solvent cement to the male end of the pipe. The amount should be more than sufficient to fill any gap. Next apply a light coat of solvent cement to the inside of the socket, using straight outward strokes to keep excess cement out of the socket.
- While both surfaces are still wet with solvent cement, insert the pipe into the socket with a quarter-turn twisting motion. The pipe must be

inserted the full length of the socket. The application of solvent cement to pipe and fitting, and the insertion of the pipe into the fitting, should be completed in less than one minute. If necessary, two persons should apply solvent cement to the pipe and fitting simultaneously.

- Hold the joint together for approximately 30 seconds until both surfaces are firmly gripped. After assembly, a properly made joint will usually show a bead of cement around its entire perimeter. This should be brushed off. It is recommended that the joint be allowed to cure for 24 hours before pressure testing or operation.

---

## Operation and Maintenance of Your Paragon® Cooling Tower

---

**Safety in Operation of the Fan**

**NEVER** operate the fan when the access panel or the entire fan guard is removed.

**NEVER** remove access manhole cover while fan is in operation.

**NEVER** operate fan when any work, access, maintenance, trouble-shooting, etc. is being performed on the inside of the fan ring assembly or inside the tower plenum.

- Normally, electrical codes dictate a disconnect box at the cooling tower.
- The handle of the disconnect box **must be locked in the off position and an OSHA DANGER tag (DO NOT OPERATE) must be attached to handle securely.**

Note: Removing fuses from the disconnect box may provide further assurance, but only when done by qualified personnel.

The foregoing precautions apply when any type of internal access to the tower is required, including the following examples:

- Checking, maintenance or replacement of any fan assembly component.
- Checking, maintenance or replacement of the water distribution system inside the tower.
- Cleaning of the fill.
- Any work that necessitates removal of any access door, the fan guard or the manhole cover.

**Water Distribution System**

Water distribution is accomplished by a low pressure, rotating, self-propelled sprinkler system designed to accommodate the specified flow rate.

The following points are important:

- Substantial deviations from specified water flow will inhibit proper sprinkler and drift eliminator functions and may necessitate replacement of the sprinkler lateral arms, calibrated for a new range of water flow.
- Normal sprinkler rotational speed is approximately 4 to 6 RPM, with both the pump and the fan operating.

- Rotation can be observed through the inspection port in the side of the tower.
- Sprinkler RPM can be adjusted by a slight rotation of the lateral arms at the sprinkler head. Counter clockwise rotation of the laterals will increase RPM. The standard position is set by aligning the center of the hexagonal bolt with the center of the slot on the sprinkler head. This angle was preset at the factory and should not require adjustment unless there is a genuine necessity to do so.

**IMPORTANT:**

Following any adjustment of lateral arm angles, eliminator blades must be re-adjusted into horizontal position.

- The maximum operating inlet water temperature should not exceed 140° F.
- The operating inlet pressure should be as follows:

Model	Measurement Location	Flow (GPM)	Pressure (PSI)
T-55i – T-125i	Ground Level	50-300	6 – 7
	Entering Tower	301-550	8 – 10
T-150i – T175i	Ground Level	100-400	5 – 6
	Entering Tower	401-800	7 – 9
T-200i – T-250i	Ground Level	150-750	6 – 8
	Entering Tower	751-1200	9 – 11

- Do not over-tighten the hexagonal bolts used for sprinkler lateral arm adjustment.
- Before start-up, check for free rotation of the sprinkler system.
- Periodically during operation, check for proper RPM at design waterflow.
- Clean out of the sprinkler lateral arms is accomplished by removing the end cap of each lateral through the side inspection clean-out port in the tower body.
- Installation of a tower outlet strainer (optional accessory) is recommended as an effective and economical means of preventing clogging of sprinkler orifices.

**CAUTION:**

When stepping on top of the fill, distribute the body weight by means of two plywood plates as described earlier in these instructions.

**Sprinkler Head Maintenance**

If the sprinkler revolution slows down or stops despite normal and proper water flow, the sprinkler head may require removal for inspection and cleaning.

*Note: Check the troubleshooting guide first for other corrective action.*

- To remove the sprinkler head, first remove the sprinkler lateral arm and drift eliminator blade assemblies. Then remove the two (2) riser pipe screws. (Refer to Figures 2 and 4).

- For proper inspection and cleaning, the sprinkler head should be removed from the tower. The steps to remove the sprinkler head follow:

1. Match mark riser pipe assembly and coupling. Remove the two (2) riser pipe screws and remove the entire sprinkler head assembly from the coupling.

*Note: It is necessary to shift the upper split layer of fill to gain access to the riser pipe screws. Remember to not step directly on any fill and to use plywood to distribute the load.*

2. The self-tapping screws and the PVC ring must be removed from the sprinkler head provided with Models ΔT-55I thru ΔT-125I prior to removal of the head body assembly. For the convenience of reassembly, match mark to PVC ring and the

lip of the sprinkler head. This procedure is not necessary for disassembly of the sprinkler head for any other model.

3. Remove the top locknut and lift the sprinkler head body assembly to separate it from the internal riser pipe.

- Inspect the general condition of all components, including the shaft seal, for wear, mechanical interference, and check for foreign matter on the frictional surfaces.
- Clean or order replacement components as necessary. Consult Factory prior to authorizing any field repairs. Work by others without Delta authorization may void warranty.
- Pack shaft seal area and space between spacer and threaded rod with Bostik "Never-Seez" sealing compound before reassembly.
- Assemble in reverse order per the above instructions.
- After assembly, check that the sprinkler head rotates freely.
- The sprinkler head should be inspected and cleaned every 2 to 3 years or more frequently depending on operating environment.

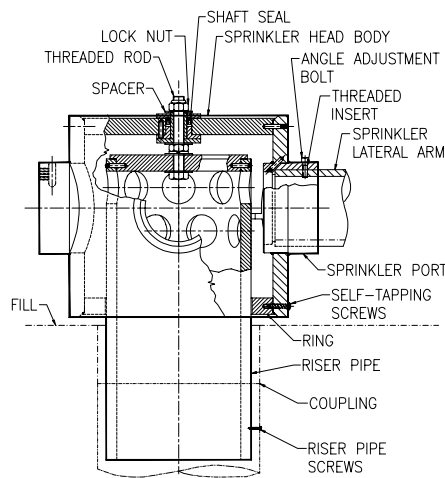

Figure 4 – 6” Sprinkler Head Assembly

**Optional Non-rotating Fixed Water Distribution System**

Delta offers an optional non-rotating spray nozzle distribution system in lieu of the standard rotating sprinkler system. For models with this option, the following items are important:

- Check spray pattern from nozzles to be sure there is no clogging by removing man way cover.
- The flow rate of the cooling tower must be as close to the design GPM as possible. The distribution system, including the spray nozzles, are provided for the design flow conditions. Under-pumping or over-pumping may cause the cooling tower to perform inefficiently.
- Design pressure at the inlet connection must be properly maintained for proper water distribution. If the pressure is less or greater than design, proper water dispersion over the internal wet decking will be impaired. If the inlet pressure is low, water spray will not cover the entire wet decking surface. This causes channeling of air and does not make maximum use of the heat transfer media. High inlet pressures will cause the water to overspray the wet decking media, hit the internal side walls of the tower shell and drop in a vertical flow along the shell walls without the opportunity for maximum water / air contact through the heat transfer media. Excessive high spray pressure may also cause wet decking fatigue and damage. Pressure of 6-8 psi is required at the nozzle for proper operation. If pressure measurement is taken at the tower inlet, an additional pressure should be added to this value to compensate for the elevation of the spray header relative to the measurement location (see table below). Correct flow rates and inlet pressures should be determined prior to completion of system installation.

Model	Measurement Location	Pressure (PSI)
T-55i – T-125i	At Nozzle	6 – 8
	Ground Level Entering Tower	9 – 11
T-150i – T-175i	At Nozzle	6 – 8
	Ground Level Entering Tower	10 – 12
T-200i – T-250i	At Nozzle	6 – 8
	Ground Level Entering Tower	11 – 13

Required pressure for optional spray nozzle distribution system

**Direct Drive Fan Assembly and Its Maintenance Safety**

Follow all safety instructions previously discussed. Before performing any inspection or maintenance on the direct drive fan assembly, power to the fan assembly must be disconnected.

### Fan Assembly:

The Air moving system is a direct drive fan assembly where the motor is connected directly to the propeller. This system has a minimal amount of moving parts and, therefore, maintenance issues are minimal.

- Delta recommends the use of Vibration Cut-Out Switches (VCOS) for the fan(s). Vibration cut-out switch provides for fan motor circuit disconnect for shutdown protection should abnormal fan vibration develop during service.

- The propeller blades have an adjustable pitch. The pitch is set in the factory prior to shipment for the proper airflow and HP.

### Motor:

- The standard motor is a NEMA Premium Efficiency, totally enclosed motor, Inverter Rated with extra moisture protection on the windings, Class F insulation, 1.15 minimum service factor, epoxy coating on outside frame, and is specifically designed for cooling tower duty to the exclusive specifications of Delta Cooling Towers.

- Should there be a problem with the motor, which may be covered under our standard warranty, the motor **must only** be inspected and serviced by an authorized agent of the motor manufacturer, otherwise the warranty is void.

- If the motor bearings have grease fittings, follow the lubrication recommendations as outlined in instructions from motor manufacturer. The majority of motors **do not require greasing**.

### Start-Up Instructions

Complete all start-up instructions before applying heat load.

- Clean any accumulated debris or packaging material from inside tower sump.
- Check to be sure that the fan motor is properly wired for correct rotation as viewed from the top of the fan. Reverse leads will cause incorrect rotation and reverse direction of airflow.

*Note: Fan rotation should always agree with rotation labels. Standard fan rotation is clockwise, (C.W.) however; non-standard fans may be designed to rotate counter clockwise, (C.C.W.)*

- Check for free rotation of the fan and fan blade tip clearance.

Tower Model #	Operating level (from bottom of sump)
ΔT-55I thru ΔT-125I	Between 13-15 inches
ΔT-150I / ΔT-175I	Between 14-16 inches
ΔT-200I / ΔT-250I	Between 15-17 inches

- Check for free rotation of the sprinkler system. This can be accomplished by removing the inspection cover and moving the lateral arms by hand.

- Extend the PVC deflectors outward under each louver panel to allow them to catch any splashes of water that may get through the louver. It's recommended to apply a bead of marine sealant along the outer edges.

- Fill the cooling tower sump or the cold water storage reservoir on gravity drain applications.

- Water recirculation pump should be primed and all piping below the tower sump filled with water. Check pump for proper shaft rotation.

- Start water recirculation pump and adjust flow to design. A flow metering device installed in the inlet is recommended but if not available, use the pressure differential across the pump in conjunction with the pump curve.

- Check flow pattern from sprinkler lateral arms to be sure there is no clogging of orifices. If necessary, clean out lateral arms by removing the end caps, which are accessible through the clean-out hole near the top of the tower.

- Start up fan motor and check amperage and voltage against motor nameplate data.

- The standard make-up valve assembly is shipped with the plastic float ball strapped against the tower side to prevent damage. To set the ball for proper operation, loosen the screw in the fulcrum arm, lift or depress the arm with the plunger pressed against the valve seat and tighten. Repeat until the proper operating level is obtained (Refer to operating level table below). It is recommended that a shut-off valve be installed in the make-up line.

- After 24 hours of operation:
  - Check lateral arms for clogging.
  - Check tower sump water level.

### Water Level in Tower Sump

- When the cooling tower is being operated with pump-suction, the make-up valve assembly with float ball should be adjusted to set the water operating level as follows:

- Remove the PVC louver closest to the make-up valve assembly to gain access to make-up valve assembly.

- A lower water level than recommended may cause air to be drawn into the tower outlet piping and cause pump "cavitation."

- A water level higher than recommended will cause continuous overflow and waste of water as a result of potential "pull-down" from the piping when the system is shut down.

- The overflow should **NEVER** be capped, or its elevation altered by raising external piping.

*Note: On gravity drain cooling towers, make-up assembly, overflow, drain and vortex breaker are not provided.*

### Cold Weather Operation

#### Cold Weather Protection

The cooling tower may require protection against freezing at light heat loads when the wet-bulb temperature is under 32°F., or during shutdown when the temperature drops below 32°F.

The following methods are recommended for use in Delta Cooling towers for protection during cold weather conditions. Recommended equipment is optional and may be ordered from the factory. Consult the factory for further information on which equipment to choose for your specific application.

#### Separate Indoor Sump

This method is virtually foolproof antifreeze protection system with the added advantage of minimum maintenance. The indoor sump tank should be large enough to fill the entire recirculation system without danger of pump cavitation. As a general rule, the tank should be sized to hold three times the rate of circulation in gallons per minute (gpm).

The tank should be provided with properly sized overflow, make-up drain and suction connections. When a separate sump is ordered with a cooling tower, the water make-up valve assembly and the overflow and drain connections are installed in the indoor sump only.

When a sump tank is used, the cooling tower should be located high enough above it to allow free cold water gravity drain. A bottom outlet can be provided for gravity drain to indoor sump tank installations. Adequate size outlet and piping is dependent on system piping configurations. Delta can provide larger outlets for free gravity flow if required.

***Reverse siphoning is a back flow of non-potable, recirculating water into a potable water system, which can occur through the make-up float valve assembly located in the water reservoir. Should the valve malfunction, blockage of the overflow or outlet lines would cause water level to rise in the reservoir, and the make-up water pressure could drop below the atmospheric pressure creating a vacuum at the make-up inlet. Although precautions to prevent reverse siphoning are incorporated in the cooling tower design, we also recommend installing a check valve in the water make-up supply line, as a backup precaution.***

#### **Electric Immersion Heater**

Cooling towers ordered with antifreeze systems are shipped with a protective seat secured under the immersion heater probe, which must remain in place during operation to protect the polyethylene shell from the heater element.

*Note: This seat is not a shipping brace and **must not be removed.***

#### **Thermostatic On/Off Control**

A thermostatically controlled fan for on/off operation, should be considered as an energy saving feature, for capacity control during winter operation. The thermostatic control can be field set to insure automatic fan shut-down when cold water drops below design temperatures, as well as fan start-up when cold water rises to design temperature.

A thermostatic control provides excellent cooling tower anti-freeze protection while reducing operating costs throughout cold weather operation.

#### **Drain Line**

To prevent damage to the PVC distribution system during cold weather shut-down, install an automatic or manual drain line from the hot water inlet piping as close to the cooling tower inlet as possible. The entire inlet and distribution system must be drained for shut-down in sub-freezing weather.

#### **Piping**

When the cooling tower is located outdoors, adequate measures including the use of heating tapes and insulation should be considered to protect water lines from freezing.

#### **Operation at Sub-freezing Ambients**

See Thermostatic On/Off control  
To prevent ice formation, insure that tower operates at maximum possible heat load.

If tower is equipped with two speed motors, operate at low speed to increase leaving water temperature.

On multi-cell installations, it may also be necessary to cycle fan(s) periodically to prevent ice formation on the intake louvers and the wet decking. If fan(s) are operated in reverse, **DO NOT**

operate in reverse any longer than is necessary. Extended reverse operation can cause ice to form on the fan blades causing an out-of-balance condition. **A vibration cut-out switch is always recommended. When reversing the fans, they should always be allowed to come to a complete stop before starting up in the opposite direction.**

The importance of frequent visual inspections and routine maintenance during sub-freezing operation is very important and should not be overlooked.

## Trouble-Shooting Guide For Paragon® Induced Draft Cooling Towers

<b>Problem</b>	<b>Possible Causes</b>	<b>Corrective Actions</b>
Increase in the leaving water temperature	<ol style="list-style-type: none"> <li>1. Excess water flow; over pumping.</li> <li>2. Recirculation of hot discharge air, back into the cooling tower air intakes. Obstructed air intakes</li> <li>3. Proximity of other heat source or discharge of moist air.</li> <li>4. Improper operation of sprinkler system.               <ol style="list-style-type: none"> <li>A. Orifices clogged.</li> <li>B. RPM too slow or sprinkler stops.                   <ol style="list-style-type: none"> <li>a. Preset angle of orifices was changed.</li> <li>b. Actual water flow is lower than design sprinkler rating.</li> <li>c. Mechanical causes.</li> </ol> </li> </ol> </li> <li>5. Clogged fill.</li> <li>6. Damaged fill.</li> <li>7. Additional heat load on system.</li> <li>8. Wet-bulb temperature higher than design.</li> </ol>	<ol style="list-style-type: none"> <li>1. Adjust to the design flow.</li> <li>2. Eliminate obstructions which impede air discharge. For proper location of cooling tower(s), see Delta dwgs. Baffle air discharge, if necessary.</li> <li>3. Remove source or relocate tower.</li> <li>4. See water distribution system instructions.               <ol style="list-style-type: none"> <li>A. Flush lateral arms, clean orifices, clean system, install outlet strainer.</li> <li>B.                   <ol style="list-style-type: none"> <li>a. Reset properly or increase angle of lateral arms.</li> <li>b. Install properly rated sprinkler lateral arms or increase to design flow.</li> <li>c. Check for clearance between lateral arms &amp; walls. Check sprinkler head. See sprinkler head maintenance.</li> </ol> </li> </ol> </li> <li>5. Clean the fill.</li> <li>6. Replace the fill.</li> <li>7. Contact Delta for possible upgrade or addition of another cooling tower selected for additional load.</li> <li>8. None required if condition is temporary. Otherwise consult Delta for upgrade.</li> </ol>
Drop in the water flow rate. Low water flow rate	<ol style="list-style-type: none"> <li>1. Blockage of sprinkler lateral arm orifices.</li> <li>2. Low water level in sump causing air to be drawn into pump and piping.</li> <li>3. Improper selection of water circulating pump.</li> <li>4. Blockage of strainers.</li> <li>5. Pump malfunction.</li> </ol>	<ol style="list-style-type: none"> <li>1. Flush lateral arms. Clean whole system. Install outlet strainer.</li> <li>2. Adjust float valves. Be sure the system is flooded and balanced.</li> <li>3. Replace with proper size pump designed for flow and head requirements. Check pump "Net positive suction head."</li> <li>4. Backwash or clean.</li> <li>5. Consult pump specialist.</li> </ol>
Noise and vibration	<ol style="list-style-type: none"> <li>1. Loose bolts.</li> <li>2. Mechanical interference of rotating parts.</li> <li>3. Fan propeller damaged or out of balance.</li> <li>4. Air intake at pump.</li> <li>5. Pump cavitation.</li> <li>6. Damaged motor bearings.</li> </ol>	<ol style="list-style-type: none"> <li>1. Recheck and tighten all bolts to specified torque.</li> <li>2. Inspect propeller for free rotation. Check propeller for mechanical interference. Adjust, repair or replace, as necessary.</li> <li>3. Replace components, as necessary and check balance. Install vibration cut-out switch.</li> <li>4. Check basin water level and irregular piping design.</li> <li>5. Match pump NPSH with system hydraulics.</li> <li>6. Check and replace motor.</li> </ol>
Sudden or short term irregularities of cold water level in basin	<ol style="list-style-type: none"> <li>1. Peculiarities of specific system and its operation.</li> </ol>	<ol style="list-style-type: none"> <li>1. Inspect system and review operation procedures. Correct, as applicable valve settings, loss of water in system, fill system to flooded capacity.</li> </ol>
Excessively high water level in sump on gravity drain installation	<ol style="list-style-type: none"> <li>1. Gravity flow restrictions due to insufficient head differential.</li> </ol>	<ol style="list-style-type: none"> <li>1. Correct if Necessary:               <ol style="list-style-type: none"> <li>A. Outlet piping should terminate below sump tank water level.</li> <li>B. Increase discharge pipe size.</li> <li>C. Increase head by means other than A.</li> </ol> </li> </ol>

<b>Problem</b>	<b>Possible Causes</b>	<b>Corrective Actions</b>
Excessively high water level in sump on gravity drain installation (continued).	<ol style="list-style-type: none"> <li>1. Airlock.</li> <li>2. Unnecessary obstruction of waterflow (i.e., partially closed valve).</li> <li>3. Undersized piping.</li> <li>4. Horizontal pipe run too long.</li> <li>5. Improper hydraulic pipe design.</li> <li>6. Outlet vortex breaker provided.</li> </ol>	<ol style="list-style-type: none"> <li>1. Install an air bleed valve at highest point of piping, usually at a vertical angle.</li> <li>2. Remove obstruction.</li> <li>3. Increase pipe size.</li> <li>4. Shorten, if possible.</li> <li>5. Correct design.</li> <li>6. Remove vortex breaker.</li> </ol>
Excessively high water level in tower basin on closed loop system installations	<ol style="list-style-type: none"> <li>1. Make-up valve float set too high.</li> <li>2. Valve or float damaged or malfunctioning.</li> <li>3. Make-up water pressure too high.</li> </ol>	<ol style="list-style-type: none"> <li>1. Readjust float arm.</li> <li>2. Repair or replace.</li> <li>3. Reduce pressure or contact Delta for alternate solutions.</li> </ol>
Uneven water level in tower basins of multi-cell installations	<ol style="list-style-type: none"> <li>1. Unbalanced system hydraulics.</li> <li>2. More than one make-up valve operating, and set for different water levels.</li> </ol>	<ol style="list-style-type: none"> <li>1. <ol style="list-style-type: none"> <li>A. Install equalizer line with isolation valves between modules.</li> <li>B. Adjust inlet water flow to insure equal distribution to each cooling tower module.</li> <li>C. Review outlet header hydraulics and correct piping design, if applicable.</li> <li>D. Contact Delta for assistance.</li> </ol> </li> <li>2. <ol style="list-style-type: none"> <li>A. Adjust float level settings relative to one another.</li> <li>B. Shut-off and or/throttle flow to one or more valves.</li> <li>C. Installation of equalizers is highly recommended.</li> </ol> </li> </ol>
Excessive water carry over (drift)	<ol style="list-style-type: none"> <li>1. Surfaces of top layer of fill damaged causing "pooling" of water.</li> <li>2. Eliminator(s) not horizontal.</li> <li>3. Damaged eliminator.</li> <li>4. Excess water flow causing high sprinkler RPM.</li> <li>5. Improper angle of sprinkler lateral arms causing high RPM.</li> <li>6. Orifices in lateral arms clogged causing improper water dispersement and high RPM.</li> <li>7. Blockage of fill.</li> </ol>	<ol style="list-style-type: none"> <li>1. Replace top layer. Protect fill when working inside tower.</li> <li>2. Adjust to horizontal position.</li> <li>3. Replace.</li> <li>4. Reduce water flow or install lateral arms designed for the actual operating flow.</li> <li>5. Reduced the angle of the lateral arms. (Rotate arms CW slightly).</li> <li>6. Install outlet strainer. Clean whole system and lateral arms.</li> <li>7. Clean fill.</li> </ol>
Premature or excessive corrosion of fan drive components	<ol style="list-style-type: none"> <li>1. Excessive drift.</li> <li>2. Presence of corrosive chemicals in air or water that was not known at time of supply.</li> </ol>	<ol style="list-style-type: none"> <li>1. See " Excessive Water Carry Over (Drift)" above.</li> <li>2. Remove source of corrosion or contact Delta for alternative materials, premium coatings or other precautions.</li> </ol>

## Motor Trouble Shooting Guide (General)

<b>Problem</b>	<b>Possible Causes</b>	<b>Corrective Actions</b>
High current draw (all 3 phases)	<ol style="list-style-type: none"> <li>1. Low line voltage (5 to 10% lower than nameplate).</li> <li>2. 200V motor on 230/240V system.</li> <li>3. 230V motor on 208V system.</li> <li>4. Incorrect propeller.</li> <li>5. Incorrect pitch adjustment</li> </ol>	<ol style="list-style-type: none"> <li>1. Consult power company.</li> <li>2. Change to 230V motor.</li> <li>3. Change to 200V or 280V motor.</li> <li>4. Consult Delta.</li> <li>5. Reduce pitch / consult Delta</li> </ol>
Low motor current draw	<ol style="list-style-type: none"> <li>1. Incorrect propeller.</li> <li>2. Incorrect pitch adjustment.</li> </ol>	<ol style="list-style-type: none"> <li>1. Consult factory</li> <li>2. Increase pitch / consult factory</li> </ol>
Unbalanced current (5% from average)	<ol style="list-style-type: none"> <li>1. Unbalanced line voltage due to:               <ol style="list-style-type: none"> <li>A. Power supply.</li> <li>B. Unbalance system loading.</li> <li>C. High resistance connection.</li> <li>D. Undersized supply lines.</li> </ol> </li> <li>2. Defective Motor.</li> </ol>	<ol style="list-style-type: none"> <li>1. Consult power company and/or electrician.</li> <li>2. Replace motor.</li> </ol>
Excessive voltage drop (2 or 3% of supply voltage)	<ol style="list-style-type: none"> <li>1. Inadequate power supply.</li> <li>2. Undersized supply lines.</li> <li>3. High resistance connections.</li> </ol>	<ol style="list-style-type: none"> <li>1. Consult power company.</li> <li>2. Increase line sizes.</li> <li>3. Check motor leads and other connections.</li> </ol>
Overload relays tripping	<ol style="list-style-type: none"> <li>1. Overload.</li> <li>2. Unbalanced input current.</li> <li>3. Single phasing.</li> <li>4. Excessive voltage drop.</li> <li>5. Frequent starting or intermittent overloading.</li> <li>6. High ambient starter temperature.</li> <li>7. Wrong size relays.</li> <li>8. Improper overload settings of adjustable relays.</li> </ol>	<ol style="list-style-type: none"> <li>1. Reduce load on motor or increase motor size.</li> <li>2. Balance supply voltage.</li> <li>3. Eliminate.</li> <li>4. Eliminate (see above).</li> <li>5. Reduce frequency of starting and overloading or increase motor size.</li> <li>6. Reduce ambient temperature.</li> <li>7. Correct size per nameplate current and service factor.</li> <li>8. Readjust to motor FL Amps x S.F.</li> </ol>
Motor runs very hot	<ol style="list-style-type: none"> <li>1. Overloaded.</li> <li>2. Blocked ventilation.</li> <li>3. High ambient temperature.</li> <li>4. Unbalanced input current.</li> <li>5. Single phased.</li> </ol>	<ol style="list-style-type: none"> <li>1. Reduce overload.</li> <li>2. Fouled fill or air restriction.</li> <li>3. Reduce ambient temperature.</li> <li>4. Balanced supply voltage.</li> <li>5. Eliminate.</li> </ol>
Motor will not start	<ol style="list-style-type: none"> <li>1. Single phased.</li> <li>2. Rotor or bearings locked.</li> </ol>	<ol style="list-style-type: none"> <li>1. Shut power off – eliminate.</li> <li>2. Shut power off – check shaft rotation.</li> </ol>
Excessive vibration (Mechanical)	Out of balance <ol style="list-style-type: none"> <li>1. Motor mounting.</li> <li>2. Motor.</li> </ol>	<ol style="list-style-type: none"> <li>1. Check to be sure motor mounting hardware is tight.</li> <li>2. Replace motor.</li> </ol>
Low current draw (all 3 leads)		See "Low Current Draw" entry in cooling Tower trouble-shooting guide.

**Note:** Consult Warranty page prior to replacing or repairing any cooling tower components. Delta recommendation and consent to remedy material and workmanship defects is necessary, to avoid breach of Warranty

### Paragon® Optional Accessories Available

- Aluminum Ladder(s) with a step platform and railing at the fan elevation **custom designed** for the cooling tower.
- Safety cage(s).
- Two speed motor(s)
- Vibration cut-out switch provides for fan motor circuit disconnect for shutdown protection should abnormal fan vibration develop during service. Installation of vibration cut-out switches **are recommended** as good design practice.
- Thermostat on/off control of fan operation through sensing the temperature of water leaving the tower.
- Basin anti-freeze system for cold weather operation.
- Skid mounted pre-piped and pre-wired pump and control systems
- Polyethylene Sump tanks up to 10,000 gallons for indoor installation for anti-freeze protection during winter operation or process requirements.
- Motor space heaters are recommended for unusually high relative humidity conditions where extreme day to night temperatures can cause excessive condensation in the motor, when in operation during this period.
- Plastic outlet sump strainer.
- Plastic equalizer fittings.
- Variable frequency drive on fan motors, controlled by temperature controller.
- High sump level switch
- Automatic drain valve

Consult factory or a Delta representative for further information and an updated list of accessories.

### Paragon® Recommended Replacement Parts

To avoid costly cooling tower downtime, the following replacement parts should be carried in inventory at the installation site:

- Make-up float, or complete make-up valve assembly.
- Fan Motor.
- Complete spare sprinkler head assembly or spray nozzle
- Fan Propeller.

When ordering, include model number and serial number of the cooling tower as it appears on the tower nameplate. Under normal conditions, shipment of factory replacement parts is made within one day after the order is received. Spare pumps and pump parts, as well as control panel components, such as fuses and heaters for magnetic starters, are also available.

### Appendices/ Reference Documents

Additional Drawings Available Upon Request:

#### Delta Drawings

- DT-D-81-756 Model ΔT-55/85I Assembly
- DT-D-81-754 Model ΔT-100/125I Assembly
- DT-D-81-755 Model ΔT-55 - 125I Single/ Multicell Layout
- DT-D-83-754 Model ΔT-150/175I Assembly
- DT-D-83-755 Model ΔT-150/175I Single/ Multicell Layout
- DT-D-80-754 Model ΔT-200/250I Assembly
- DT-D-80-755 Model ΔT-200/250I Single/ Multicell Layout
- DT-B-80-520 Ladder Installation Instructions
- DT-B-78-001 Wiring Schematic, 3 phase
- DT-B-78-005 Wiring Schematic, 2 speed
- DT-B-78-006 Wiring Schematic, 1 phase
- DT-B-78-008 Wiring Automatic Drain
- DT-B-78-015 Wiring High Sump Level Switch
- DT-B-78-011 High Sump Level Switch & Electronic Make Up Package
- DT-B-78-010 Heater Support Detail
- DT-A-80-517 Vibration Switch
- DT-B-80-525 Antifreeze Immersion Heater Package
- DT-B-78-007 Fan Thermostat
- DT-B-80-540 Automatic Drain Valve

## Preventative Maintenance Checklist

Procedure	Monthly	Every 3 Months	Every 6 months
Inspect <b>General Condition</b> of cooling tower.	√		
Check <b>Water Level</b> in cold water basin. Adjust if needed.	√		
Check float ball & <b>Make-up Valve</b> for proper operation.	√		
Check <b>Line Voltage, Motor Amperage, Water Pressure.</b>	√		
Clean <b>Sump Strainers</b> , if installed.	√		
Lubricate Motor Bearing, (if motor has fittings for greasing. The majority of motors require no external greasing). Use <b>Proper Lubricants</b> . Increase frequency, as necessary depending on conditions of service.		√	
Check for obstructed <b>Water Flow Through Orifices</b> . Clean and flush spray nozzles, as required.		√	
<b>Check All Bolts</b> which can cause unbalance and vibration and tighten specified torque.		√	
Check <b>Condition of Water</b> for proper treatment to prevent build-up of algae and solids concentration		√	
Clean and flush <b>Cold Water Sump</b>			√

## Conditions of Sale and Warranty

### Terms and Conditions

1. **Sale Not a Consumer Transaction:** Buyer agrees that the purchase of Delta's Products (hereinafter "Product") is not for consumer, household or family purposes.
2. **Agreement of Sale: Acceptance:** Any acceptance contained herein is expressly made conditional on Buyer's assent to any terms contained herein that are additional to or different from those proposed by Buyer in its purchase order and hence any terms and provisions of Buyer's purchase order which are inconsistent with the terms and conditions hereof shall not be binding on the Seller. Unless Buyer shall notify Seller in writing to the contrary as soon as practicable after receipt hereof, acceptance of the terms and conditions hereof by Buyer shall be deemed made and, in the absence of such notification the sale and shipment by the Seller of the goods covered hereby shall be conclusively deemed to be subject to the terms and conditions hereof.
3. **Entire Contract:** This contract constitutes the final and entire agreement between Seller and Buyer and any prior or contemporaneous understandings or agreements, oral or written are merged herein. The sales and technical representatives of the Seller are not authorized to make warranties about the product. Sellers representatives' oral statements do not constitute warranties, shall not be relied upon by the Buyer, and are not part of the contract for sale. Any product-literature and operating instructions, and statements contained therein, do not constitute warranties, shall not be relied upon by the Buyer and are not part of the contract for sale. The entire contract is embodied in this writing and no other warranties are given beyond those set forth in this contract. This writing constitutes the final written expression of the parties agreement, and it is a complete an exclusive statement of the terms of the agreement.
4. **Prices:** Except where expressly agreed, all prices are subject to change without notice. If there is a delay in approval of drawings related to this contract beyond 30 days, an escalation in selling price may occur due to a rise in labor and/or material prices.
5. **Taxes:** The price of goods does not include sales, use, excise, ad valorem, property or other taxes now or hereinafter imposed, directly or indirectly by any governmental authority or agency with respect to the manufacture, production, sale, delivery, consumption or use of goods covered by this contract. Buyer shall pay such taxes directly or reimburse Seller for any such taxes which it may be required to pay.
6. **Payment:** The specific terms of payment are as specified in writing by Seller. If the Buyer shall fail to make any payments in accordance with the terms and provisions hereof, the Seller, in addition to its other rights and remedies, but not in limitation thereof, may, at its option, defer shipments or deliveries hereunder, or under any other contract with the Buyer, except upon receipt of satisfactory security or of cash before shipment.
7. **Shipment; Risk of Loss Title:** The goods shall be shipped FOB Seller's shipping points. Risk of loss shall pass to Buyer upon delivery to the carrier. Title shall pass to Buyer on delivery to the carrier.
8. **Delivery; Delays in Deliveries:** The date of delivery provided herein is an approximation based on Seller's best judgement. Seller shall be excused for delay in delivery, may suspend performance and shall under no circumstances be responsible for failure to fill any orders when due to acts of God or of the public enemy; fires; floods; riots; strikes, freight embargos or transportation delays; shortage of labor; inability to secure fuel; material supplies, or power at current prices or on account of shortages thereof; any existing or future laws or acts of the Federal or of any State Government (including specifically, but not exclusively, any orders, rules or regulations issued by any official or agency of any such government).
9. **LIMITED WARRANTY:** Seller warrants that the cylindrical, seamless molded polyethylene shell of the Product shall be free from defects in materials and

workmanship and will not peel, chip, rust or need painting for a period of fifteen (15) years from the date of shipment. Since the Product once in operation is under the sole control of the User, this warranty is further subject to and shall be applicable only if all of the following conditions are met:

- a. The Product has been properly erected in accordance with the Seller's instructions and in accordance with good installation practices;
- b. Seller's instructions and recommendations as to operation and maintenance have been followed, including those contained in the manual furnished with the Product;
- c. The Product has been used under normal operating conditions;
- d. The Product has not been affected by misuse, neglect, accident or abrasion;
- e. The User has not attempted or performed corrective work on the Product without Seller's prior written consent; and
- f. The Seller shall have received notice of any defect no later than 10 days after User first has knowledge of same.

Except where expressly noted otherwise, Seller warrants all Product components, other than moving parts, against defects in workmanship and material for a period of one (1) year from the date of shipment, provided the equipment has been properly maintained and operated under normal conditions.

Motors and blowers carry a normal manufacturer's one (1) year warranty against defects in workmanship and materials beginning from the date of shipment and subject to the same conditions of proper use and operation as other components of the Product. Bearings, pulleys, belts or other moving parts and components are sold without any warranty.

10. **DISCLAIMER OF ALL OTHER WARRANTIES AND GUARANTEES:** The aforesaid warranty is the sole and only warranty or guarantee relating to the product provided under this Agreement, and is in substitution for, and in lieu of, any and all other warranties, written or oral, expressed, implied or statutory including any warranty of merchantability or of fitness for a particular purpose.

### 11. CORRECTION OF DEFECTS AS SOLE

**REMEDY:** If the Buyer/User gives the Seller written notice of defects in the product within any period of warranty described herein and the Seller's inspection confirms the existence of such defect, the Seller, at its option, shall correct the defect or defects either by repair, providing repair tools and instructions, or replacement, FOB Seller's shipping point, or refund the purchase price of the product. The remedies provided Buyer/User herein for breach of Seller's warranty shall be exclusive.

No expense, liability or responsibility will be assumed by the Seller for repairs made by other than Seller's agent without written authority from the Seller.

Remedial action, in the manner and for the period of time provided above, shall constitute fulfillment of all liabilities of Seller to the Buyer / User, and Buyer/User's sole remedy hereunder, whether based on contract, tort or otherwise. The sole purpose of stipulated exclusive remedy shall be to provide the User with free repair and replacement of defective parts in the manner provided herein. This exclusive remedy shall not be deemed to have failed of its essential purpose so long as the Seller is willing and able to repair or replace defective parts in the prescribed manner.

An action for breach of this limited warranty or any other action otherwise arising out of this contract must be commenced within one (1) year from the date the right, claim, demand or cause of action shall first occur, or be barred forever.

### 12. STATEMENT OF BUYER/USER'S

**RESPONSIBILITIES:** It is the sole responsibility of the Buyer/User, and not in any manner the responsibility of the Seller, to test, control and properly dispose of all discharges, both gaseous and liquid, from the product to assure:

- a. Compliance with all federal, state and municipal (or any political subdivision thereof) statutes, laws, codes, ordinances, rules and regulations concerning the environment, including but not limited to: The Clean Air Act, 42 U.S.C. S7401 *et seq.*; The Clean Water Act, 33 U.S.C. S1251 *et seq.*; The Comprehensive Environmental Response, Compensation and Liability Act, 42 U.S.C. S9601 *et seq.*; The Toxic Substance Control Act, 15 U.S.C. S2601 *et seq.*; The Resource Conservation and Recovery Act, 42 U.S.C. S6901 *et seq.*; The Safe Drinking Water Act, 21 U.S.C. S349 *et seq.*; The National Environmental Policy Act, 42 U.S.C. S4321 *et seq.*; Occupational Safety and Health Act, 29 U.S.C. S651 *et seq.*; together with any amendments thereto and regulations promulgated thereunder;
- b. Adequate protection for the health and safety of people, property, wildlife and environment; and
- c. Adequate protection for all persons, including employees, coming in contact with the Product and its discharges for all purposes including, without limitation, installation, maintenance, use and repair of the Product.

It is also the sole responsibility of the Buyer/User to:

- d. Maintain the Product in accordance with the "Installation, Operating and Maintenance Instructions";
- e. Comply with the maintenance checklist contained in the "Installation, Operating and Maintenance Instructions"; and
- f. Periodically monitor and test the Product to verify proper functioning, and to insure the Product performs properly.

It is further the sole responsibility of the Buyer/User to comply with all laws, codes, and regulations relating to the Product and its use and Seller makes no warranty or representation with respect thereto.

Buyer/User assumes the responsibility for providing and installing all devices required to protect the health and safety of people, property, wildlife and the environment.

Buyer/User acknowledges having read the "Installation, Operating and Maintenance Instructions", including all warnings contained therein, and is aware of the precautions recommended for protection to the health and safety of people, property, wildlife, and the environment, including employees coming in contact with the Product discharges.

Buyer/User assumes full responsibility to assure proper use of the Product, including the determination and control of what chemicals, pollutants and toxic substances are introduced into the product, and the determination and control of all discharges from the Product.

### 13. DISCLAIMER OF TORT, CONTRACT,

**STATUTORY AND ALL OTHER LIABILITY:** The Seller hereby disclaims all tort, contract or statutory liability to the Buyer/User, and any other basis of liability to Buyer/User regarding claims for injury or damage to people, property, wildlife, or the environment, including, without limitation, claims of negligence, strict product's liability, breach of warranty (except the limited warranties as provided in paragraph 9 entitled: "Limited Warranty"), breach of contract or violation of statute, law, ordinance, code, rule or regulation. Seller also disclaims any liability to the Buyer/User in contribution or indemnification for the Buyer/User's liability or alleged liability to any third person or entity for injury or damage to people, property, wildlife or the environment. Without limiting the generality of the foregoing, Seller disclaims liability for all claims for compensatory, consequential, incidental or other damages and for damages for personal injury and

property damage, loss of use, revenue or profit, injury to good will, inability to fulfill contracts to third parties, other economic loss, response costs and other environmental clean-up costs or other damages arising out of the actual, alleged or threatened discharge, dispersal, release or escape of pollutants, contaminants, hazardous waste, or liquid or gaseous materials discharged from or through the Product and any loss, cost or expense arising out of any governmental or other direction or request to test for, monitor, clean-up, remove, contain, treat, detoxify or neutralize the foregoing. Seller also disclaims liability for all claims for damages arising from the actual or alleged violation of any federal, state, municipal (or political subdivision thereof) statute, law, ordinance, code, rule or regulation relating to the environment, including but not limited to: The Clean Air Act, 42 U.S.C. S7401 *et seq.*; The Clean Water Act, 33 U.S.C. S1251 *et seq.*; The Comprehensive Environmental Response, Compensation and Liability Act, 42 U.S.C. S9601 *et seq.*; The Toxic Substances Control Act, 15 U.S.C. S2601 *et seq.*; The Resource Conservation and Recovery Act, 42 U.S.C. S6901 *et seq.*; The Safe Drinking Water Act, 21 U.S.C. S349 *et seq.*; The National Environment Policy Act, 42 U.S.C. S4321 *et seq.*; Occupational Safety and Health Act, 29 U.S.C. S651 *et seq.*; together with any amendments thereto and regulations promulgated thereunder.

Seller further disclaims any liability, direct or indirect, resulting from the Buyer/User's failure to fulfill the responsibilities enumerated in the preceding paragraph entitled "Statement of Buyer/User's Responsibility" including without limitation:

- a. Buyer/User's failure to comply with statutes, laws, codes, rules and regulations relating to the Product and the environment; and
- b. Buyer/User's failure to provide and install all devices required for the protection of the safety and health of people, property, wildlife and the environment and all persons, including employees of the User coming in contact with the Product and its discharges; and
- c. Buyer/User's failure to adhere to the "Installation, Operating and Maintenance Instructions" and the product literature, including all warning contained therein;
- d. Buyer/User's failure to test and monitor the functioning of the Product; and
- e. Buyer/User's failure to determine and control the safety and cleanliness of discharged effluents, both gaseous and liquid, from the Product.

14. **EXCULPATORY AND INDEMNIFICATION**

**AGREEMENT:** Buyer/User hereby agrees that the Seller will not be liable to the Buyer/User for the matters referred in paragraph 13 entitled "Disclaimer of Tort, Contract, Statutory and All Other Liability." This exculpatory agreement applies even if the defect and/or loss, damage or injury to persons, property, wildlife and the environment resulted solely or in part from the Seller's actual or alleged negligence, breach of warranty, violation of a statute, law, ordinance, rule or regulation, or actions resulting in strict liability.

The Buyer/User hereby agrees to defend, hold harmless and indemnify the Seller and Seller's agents from and against all claims, suits, actions, and liabilities for injury or damage to people, property, wildlife, or the environment, including, without limitation, claims of negligence, strict products liability, breach of warranty (except the limited warranties provided in paragraph 9 entitled "Limited Warranty"), breach of contract or violation of statute, law, ordinance, code, rule or regulation.

The Buyer/User hereby agrees to defend, hold harmless and indemnify the Seller and Seller's agents from and against all claims, suits, and actions including claims for contribution or indemnification for another's liability or alleged liability to any third person or entity for injury or damage to people, property, wildlife or the environment.

Without limiting the generality of the foregoing, the Buyer/User hereby agrees to defend, hold harmless and indemnify the Seller and Seller's agents from and against all claims, suits, actions, and liabilities for

Form Dt-1170, Effective 4/98  
© 1980 Delta Cooling Towers  
All Rights Reserved

compensatory, consequential, incidental or other damages and for damages for personal injury and property damage, loss of use, revenue or profit, injury to good will, inability to fulfill contracts to third parties, other economic loss, response costs and other environmental clean-up cost or other damages arising out of the actual, alleged or threatened discharge, dispersal, release or escape of pollutants, contaminants, hazardous waste, or liquid or gaseous materials discharged from or through the Product and any loss, cost or expense arising out of any governmental or other direction or request to test for, monitor, clean-up, remove, contain, treat, detoxify or neutralize the foregoing.

The Buyer/User hereby agrees to defend, hold harmless and indemnify the Seller and Seller's agents from and against all claims, suits, actions, and liabilities for damages arising from the actual or alleged violation of any federal, state, municipal (or political subdivision thereof) statute, law, ordinance, code, rule or regulation relating to the environment, including but not limited to: The Clean Air Act, 42 U.S.C. S7401 *et seq.*; The Clean Water Act, 33 U.S.C. S1251 *et seq.*; The Comprehensive Environmental Response, Compensation and Liability Act, 42 U.S.C. S9601 *et seq.*; The Toxic Substances Control Act, 15 U.S.C. S2601 *et seq.*; The Resource Conservation and Recovery Act, 42 U.S.C. S6901 *et seq.*; The Safe Drinking Water Act, 21 U.S.C. S349 *et seq.*; The National Environment Policy Act, 42 U.S.C. S4321 *et seq.*; Occupational Safety and Health Act, 29 U.S.C. S651 *et seq.*; together with any amendments thereto and regulations promulgated thereunder.

The Buyer/User hereby agrees to defend, hold harmless and indemnify the Seller and Seller's agents from and against all claims, suits, actions, and liabilities, direct or indirect, resulting from the Buyer/User's failure to fulfill the responsibilities enumerated above in number 12 entitled "Statement of Buyer/User's Responsibilities" as if the Buyer were the User as referred to therein, including without limitation:

- a. Buyer/User's failure to comply with statutes, laws, codes, rules and regulations relating to the Product and the environment; and
- b. Buyer/User's failure to provide and install all devices required for the protection of the safety and health of people, property, wildlife and the environment and all persons, including employees of the User coming in contact with the Product and its discharges; and
- c. Buyer/User's failure to adhere to the "Installation, Operating and Maintenance Instructions" and the product literature, including all warning contained therein;
- d. Buyer/User's failure to test and monitor the functioning of the Product; and
- e. Buyer/User's failure to determine and control the safety and cleanliness of discharged effluents, both gaseous and liquid, from the Product.

The Buyer/User hereby agrees to defend, hold harmless and indemnify the Seller and Seller's agents from and against all claims, suits, actions, and liabilities as enumerated above without limitation even if said claims, suits, actions, and liabilities are based upon actual or alleged negligence, breach of warranty (other than the limited warranty provided in paragraph 9 entitled "Limited Warranty"), violation of any law, statute, ordinance, rule or regulation, or any other basis of liability on the part of Seller or Seller's agents.

15. **Assignment:** No right or interest in this contract shall be assigned by Buyer/User without prior written agreement by the Seller. No delegation of any obligation by the Buyer/User shall be made without prior written agreement by the Seller.

16. **Modifications; waiver:** No Waiver, alteration or modification of any of the provisions hereof shall be binding on the Seller unless made in writing and agreed to by a duly authorized official of the Seller. No waiver by the Seller of any one or more defaults by the Buyer/User in the performance of any provision of this contract shall per se be construed as a waiver of any future default or defaults whether of a like or of a different character.

17. **Changes & Improvements:** Seller reserves the right to make changes, and improvements in its Products at any time without notice. Where such change and improvements have been made, Seller

shall not be obligated to incorporate such changes and improvements in Products previously sold to any customer, nor shall Seller be obligated to replace previously sold products with products incorporating such changes and improvements.

18. **Return of Goods:** Where Seller has provided prior written authorization, Seller will accept the return for credit or exchange of products which have been made to the specifications set forth in its catalogs and other literature, provided the product has not been altered or damaged. Products returned for credit will be subject to a 20% restocking charge. Return products must be shipped prepaid to Seller at the location noted in written authorization.

19. **Technical Services:** Upon request of Buyer/User, Seller will endeavor to furnish such technical advice as it has available in reference to the use of its products. Any technical advice furnished by Seller with reference to the use of its products is given and accepted at Buyer/User's risk and the Seller assumes no obligation or liability for the advice given or results obtained.

20. **APPLICABLE LAW:** The validity, interpretation and performance of all terms, conditions, warranties, disclaimers, indemnification and exculpatory provisions, and all other provisions described herein, and any purchase or sale made hereunder shall be governed by the law of New Jersey in force at the date this contract is made. Where not modified by the terms herein, the provision of Article 2 of the Uniform Commercial Code as enacted by the State of New Jersey shall apply to this transaction.

21. **SEVERABILITY:** If any provision or clause of this contract or application thereof to any person or circumstances is held invalid or unconscionable such invalidity or unconscionability shall not affect other provisions or applications of the contract which can be given effect without the invalid or unconscionable provision or application, and to this end the provisions of the contract are declared to be severable.

22. **WAIVER:** If the Seller, at its option, agrees to a waiver of any of the terms and conditions recited herein, such waiver shall not for any purpose be construed as a waiver of any succeeding breach of the same or any other terms or conditions of said contract; nor shall such a waiver be viewed as a course of performance.

**BUYER/USER'S ACKNOWLEDGMENT:** User/Buyer acknowledges that he has read both sides of this contract